

# VARIABLE AREA FLOW METERS OMEGA®

## Flow Reference Section

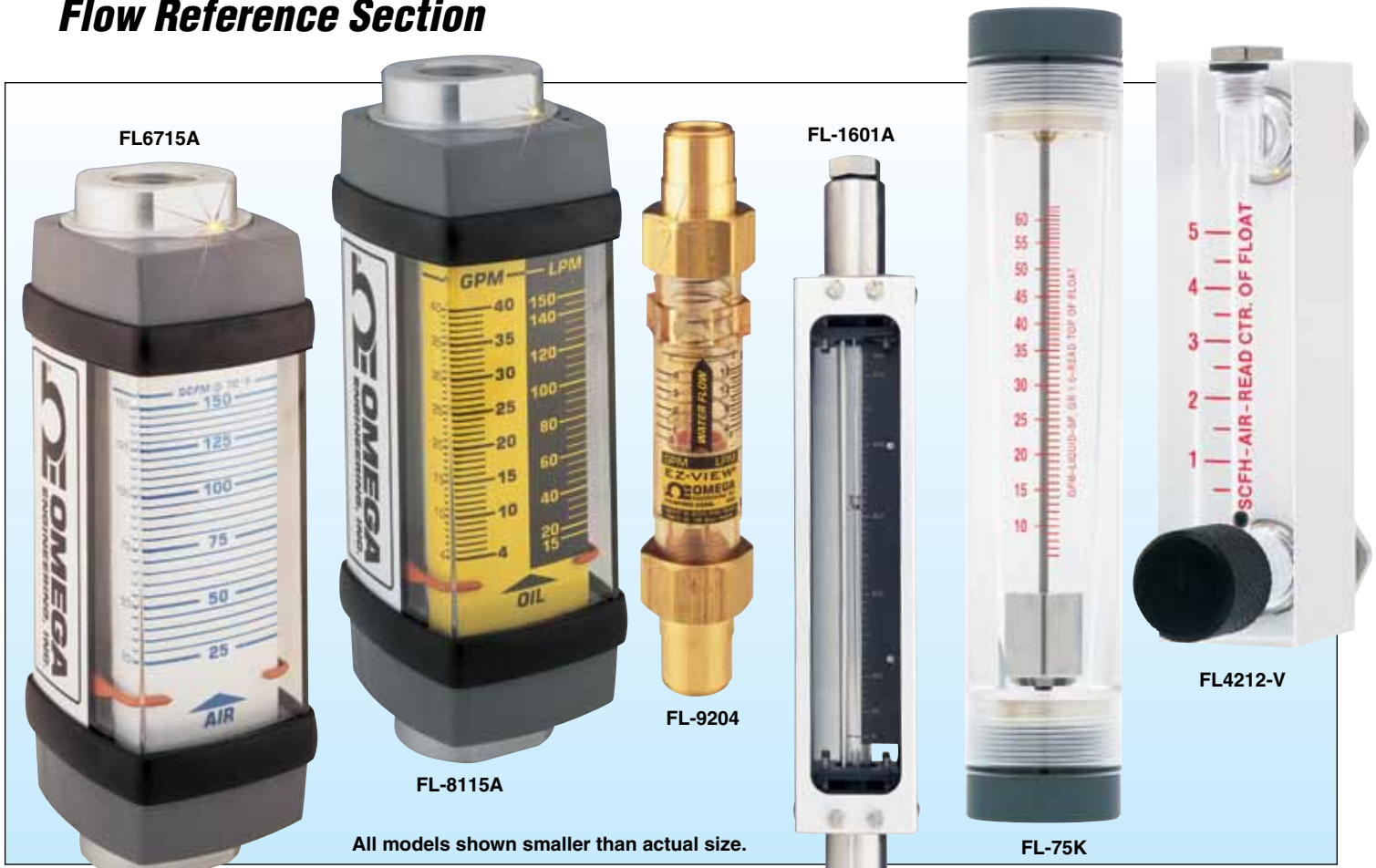

All models shown smaller than actual size.

### Introduction

Variable area flowmeters are very simple yet versatile flow measurement devices for use on all types of liquids, gases and steam. They operate on the variable area principle, whereby a flowing fluid changes the position of a float, piston, or vane to open a larger area for the passage of the fluid. The position of the float, piston, or vane is used to give a direct visual indication of the flowrate. The variable area family of flowmeters includes the following features and capabilities:

- Flowrate Meters and Controllers
- Measurement of Liquids and Gases
- Direct Visual Indication
- Low Pressure Drop
- 6 to 76 mm (¼ to 3") Typical Size
- Visual, Transmitting and Alarm Models
- Up to 2% of Reading Accuracy
- Up to ¼% of Reading Repeatability
- Simple to Install and Maintain
- No Up- or Downstream Piping Limitations
- Broad Rangeability

- Glass, Plastic and Metal Tube Designs
- Especially Suited for Low Flowrate Metering
- Piston and Vane Units Can Be Mounted in Any Position

### Rotameters

The rotameter is an industrial flow meter used to measure the flowrate of liquids and gases. Its operation is based on the variable area principle: fluid flow raises a float in a tapered tube, increasing the area for passage of the fluid. The greater the flow, the higher the float is raised. The height of the float is directly proportional to the flowrate. With liquids, the float is raised by a combination of the buoyancy of the liquid and the velocity head of the fluid. With gases, buoyancy is negligible, and the float responds to the velocity head alone.

The float moves up or down in the tube in proportion to the fluid flowrate and the annular area between the float and the tube wall.

The float reaches a stable position in the tube when the upward force exerted by the flowing fluid equals the downward gravitational force exerted by the weight of the float. A change in flowrate upsets this balance of forces. The float then moves up or down, changing the annular area until it again reaches a position where the forces are in equilibrium. To satisfy the force equation, the rotameter float assumes a distinct position for every constant flowrate. However, it is important to note that because the float position is gravity dependent, rotameters must be vertically oriented and mounted. The rotameter is popular because it has a linear scale, a relatively long measurement range, and low pressure drop. It is simple to install and maintain. It can be manufactured in a variety of construction materials and designed to cover a wide range of pressures and temperatures. The rotameter can easily be sized or converted from one kind of service to another. In general, it owes its wide use to its versatility of construction and applications.

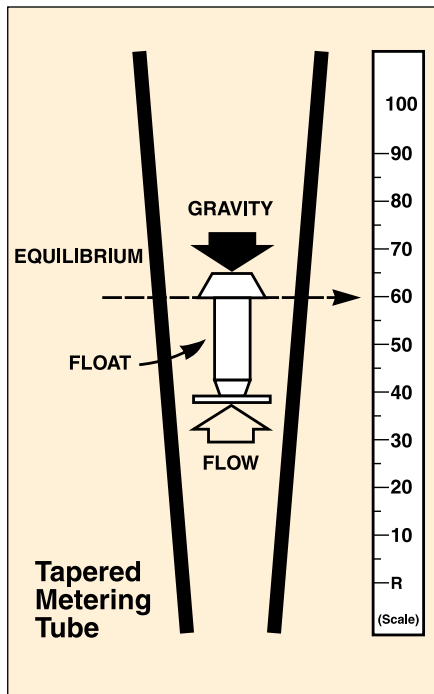

Variable area flow meter, also called a rotameter, has a float that moves up or down in a tapered tube. The distance it moves is proportional to the liquid flowrate and the annular area between the float and the tube well.

### Glass Tube Rotameters

The basic rotameter is the glass tube indicating-type. The tube is precision formed of borosilicate glass, and the float is precisely machined from metal, glass or plastic. The metal float is usually made of stainless steel to provide corrosion resistance. The float has a sharp metering edge where the reading is observed by means of a scale mounted alongside the tube. End fittings and connections of various materials and styles are available. The important elements are the tube and float, often called the tube-and-float combination, because it is this portion of the rotameter which provides the measurement. In fact, similar glass tube and stainless steel float combinations are generally available, regardless of the type of case or end fittings the application can demand, so as best to meet customer requirements. The scale of the rotameter can be calibrated for direct reading of air or water, or it may have a scale to read a percent of range or an arbitrary scale to be used with conversion equations or charts. Safety-shielded glass tube rotameters are in general use throughout industry for measuring both liquids and gases. They provide flow capacities to about 60 GPM, and are manufactured with end fittings of metal or plastic to meet the chemical characteristics of the fluid being metered.

The only fluids for which these meters are not suited are those which attack glass metering tubes, such as water over 90°C (194°F), with its high pH which softens glass; wet steam, which has the same effect; caustic soda, which dissolves glass; and hydrofluoric acid, which etches glass.

The primary limitations of general purpose rotameters are the pressure and temperature limits of the glass metering tube. Small, 6 mm (1/4") tubes are suitable for working pressures up to 500 psig, but the operating pressure for a large 51 mm (2") tube may be as low as 100 psig. The practical temperature limit for glass rotameters is 204°C (400°F), although operation at such high temperatures substantially reduces the operating pressure of the meter. In general, there is a linear relationship between the operating temperature and pressure.

### Metal Tube Rotameters

For higher pressures and temperatures beyond the practical range of glass tubes, metal tubes are used. These are usually manufactured of stainless steel, with stainless steel floats. The position of the float is determined by magnetic or mechanical followers that can be read from the outside of the stainless steel metering tube. As with glass tube rotameters, the tube-and-float combination determines the flowrate, and the fittings and materials of construction must be chosen so as to satisfy the demands of the applications.

These meters are used for services where high operating pressure or temperature, water hammer, or other forces would damage glass metering tubes. Like the general purpose type, armored rotameters can be used for most fluids, including corrosive liquids and gases. They are particularly well suited for steam applications, where glass tubes are unacceptable.

### Plastic Tube Rotameters

Plastic tubes are also used in some rotameter designs due to their lower cost and high impact strength. They are typically constructed of polycarbonate, with either metal or plastic end fittings. With plastic end fittings, care must be taken in installation, not to distort the threads. Rotameters with all plastic construction are available for applications where metal wetted parts cannot be tolerated, such as with deionized water or corrosives.

### Sizing Rotameters

The reading of a rotameter is dependent upon the nature of the fluid being metered. Rotameters are typically supplied with either a direct reading scale for air or water, or calibration data for air and water. It is therefore necessary to perform mathematical calculations when using rotameters with other fluids.

Because of its functional advantages the rotameter is an exceptionally practical flow measurement device. The pressure drop across the float is low and remains essentially constant as the flowrate changes. Float response to flowrate changes is linear, and a 10-to-1 flow range or turndown is standard. In the case of OMEGA® laboratory rotameters, far greater rangeability is possible through the use of correlation equations. Rotameters can be installed directly adjacent to pipe fittings without adverse effects on their metering accuracy, and the meters are inherently self-cleaning. Flowing between the tube wall and the float, the fluid provides a scouring action which discourages the build-up of foreign matter.

Variable area flow meters are used primarily to set flowrates. The operator observes the meter, and adjusts the valve to bring the process flow to the proper flowrate.

The meter's ability to repeat or reproduce this flowrate is of primary importance. Rotameters are repeatable up to ±1/4% of the instantaneous flowrate. This feature enables the operator to reset or adjust the flow with confidence.

# VARIABLE AREA FLOW METERS

## Flow Reference Section

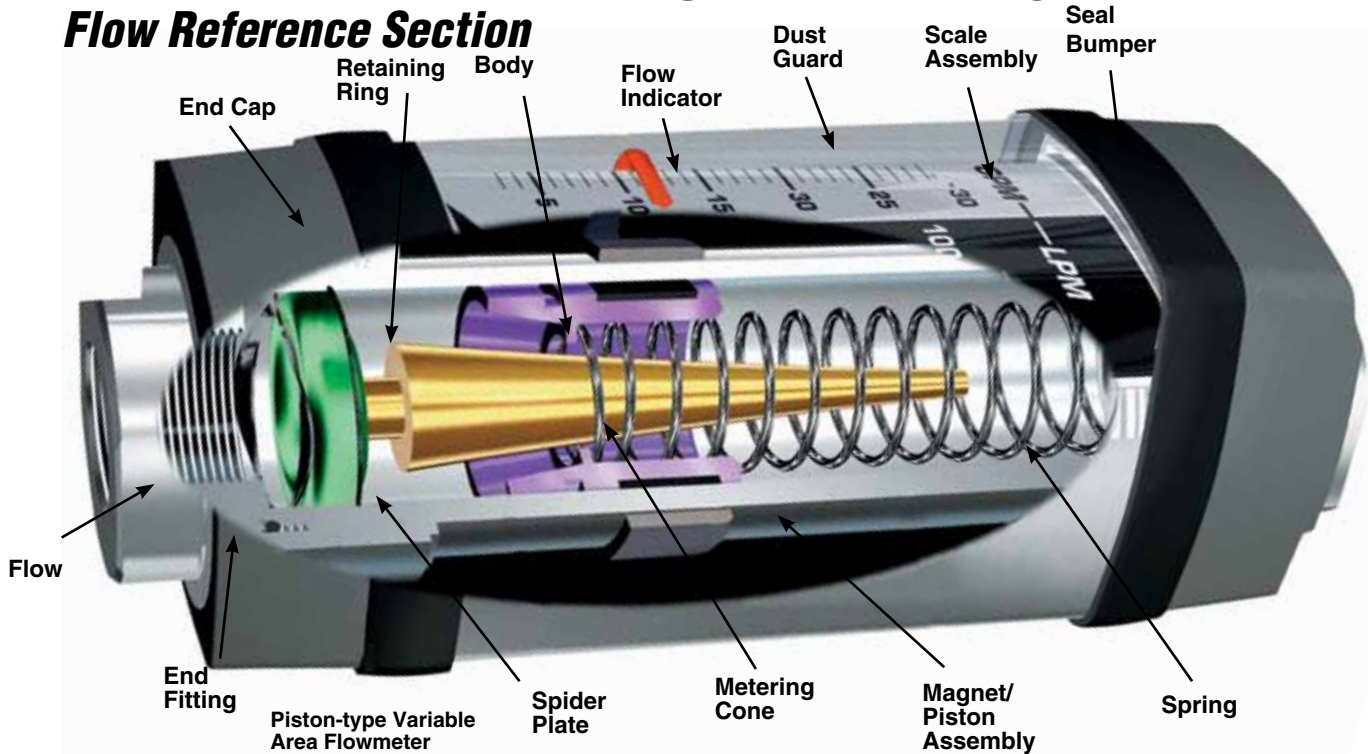

- A. INLET PORT
- B. FLAPPER VANE
- C. OUTLET PORT
- D. SPRING
- E. ENLARGED AREA TO ALLOW HIGHER FLOWS WITH NO INCREASE IN PRESSURE DROP
- F. INDICATING POINTER
- G. CAM
- H. SWITCH

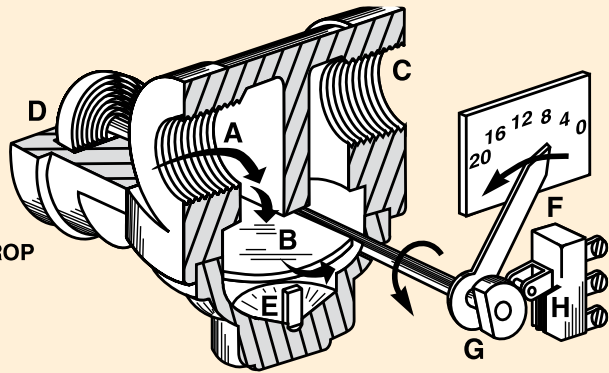

Flowmeters Operating Principle of FL-X Series

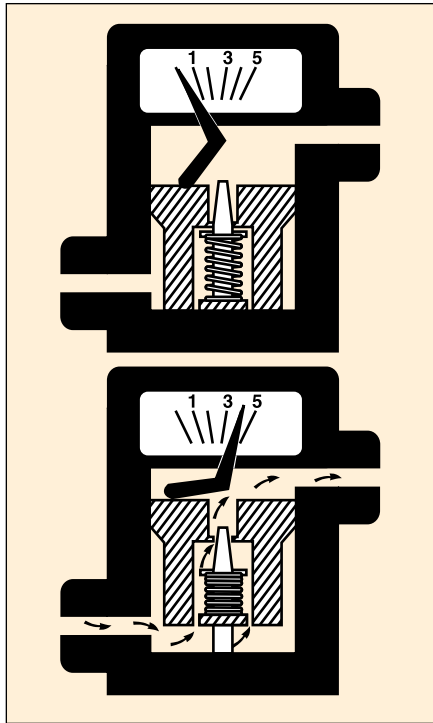

Flowmeters Operating Principle of FL-O Series

### General Purpose Rotameters For Liquids:

water equivalent =  
 GPM metered liquid flow x  

$$\sqrt{\frac{(SGF-1) \times SGL}{(SGF - SGL)}}$$

where:  
 SGL= specific gravity of metered liquid at operating conditions and  
 SGF= specific gravity of rotameter float.

This equation converts the reading of a rotameter calibrated for water to a reading appropriate for another fluid of different density. Most rotameters are very sensitive to liquid viscosity, and this equation does not take viscosity into account. Therefore, it must be considered to provide only a rough approximations.  
 Specific gravity of Glass = 2.53  
 Specific gravity of 316 SS = 8.04

### For Gases:

GPM SCFM air flow from rotameter reading = SCFM true gas flow rate x  

$$\sqrt{\frac{(SG) (T_0) (14.7)}{(1.0) (530) (P_0)}}$$

where:  
 SG = specific gravity of metered gas (air = 1.0) at STP  
 T0=temperature at operating conditions, Rankine (F + 460)  
 P0 = pressure at operating conditions in psia = (psig + 14.7).

This formula converts the metered flow, making allowance for the operating temperature and pressure, to an equivalent flow of air in SCFM at 21°C (70°F) and 14.7 psia. Capacity tables are in SCFM at standard temperature and pressure of 14.7 psia and 21°C (70°F).

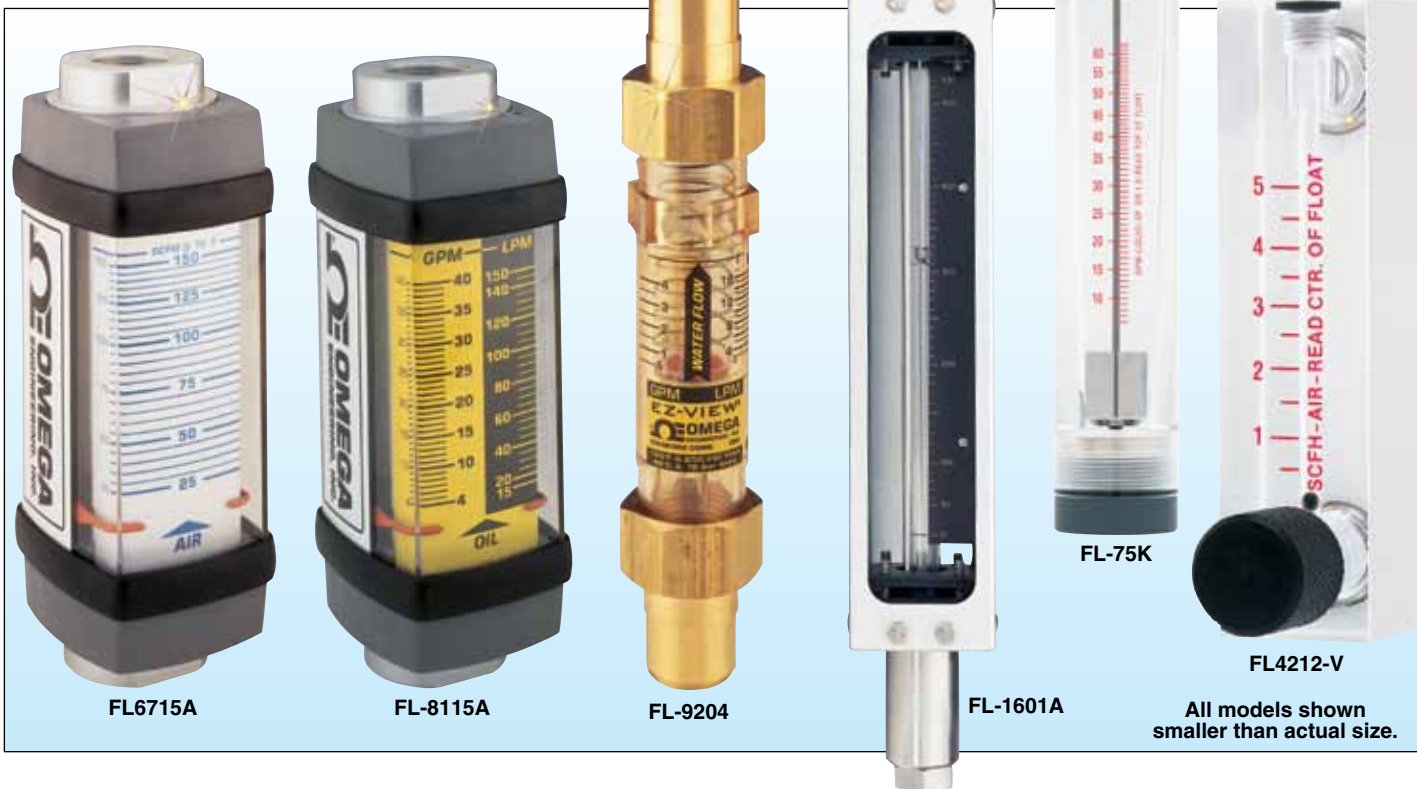

FL6715A

FL-8115A

FL-9204

FL-1601A

FL-75K

FL4212-V

All models shown smaller than actual size.

When used with purge rotameters (meters with +10% full scale accuracy) these equations are satisfactory, although not precise. When used with ±2% full scale accuracy meters, the correlation holds as long as the viscosity of the fluid does not exceed 6 centistokes. Above this viscosity, field calibration is required.

**General Purpose Rotameters**

**FL-1800 Series**

General purpose glass tube rotameters with ball floats cannot be correlated with precision, due to their strong sensitivity to variations in viscosity. OMEGA FL-1800 Series (page B-29) rotameters are supplied with correlation charts for numerous gases at various temperatures and pressures. For highest precision, field calibration is recommended.

**Piston and Vane Type Variable Area Flow meters**

Piston-type flow meters use an annular orifice formed by a piston and a tapered cone. The piston is held in place at the base of the cone (in the “no flow position”) by a calibrated spring. Flow through

that moves the piston against the spring. Piston movement and orifice area are proportional to flowrate. In case of the vane-type units, the fluid flow forces the vane to rotate against a spring, increasing the orifice area for flow. The position of the piston or vane is then read on a scale to give the flowrate. Since the force of a spring opposes the flow (in comparison to rotameters, which use gravity), these units may be mounted in any position. Scales are based on specific gravities of 0.84 for oil meters, and 1.0 for water meters. Their simplicity of design and the ease with which they can be equipped to transmit electrical signals has made them an economical alternative to rotameters for flowrate indication and control.

**Correlation of Spring and Piston Flow meters**

Although normally calibrated for oil or water, these units can be used for other fluids as well. The reading on the flow meter must be multiplied by the following correction factors to account for fluid density:

$$\sqrt{0.84/\text{spec. grav.}} \text{ (for oil meters) or } \sqrt{1.0/\text{spec. grav.}} \text{ (for water meters)}$$

These units are only slightly affected by viscosity, and no correction is normally required.

**Correlation of Spring and Piston Flow meters**

These units are calibrated to indicate standard cubic feet per minute (SCFM) of air at 100 psig and 21°C (70°F). When used at other conditions, the following corrections apply:

$$\text{SCFM (true flowrate)} = \text{SCFM (indicated)} / (f_1 \times f_2 \times f_3) \text{ where:}$$

$$f_1 = \sqrt{114.7 / (14.7 + \text{operating psig})}$$

$$f_2 = \sqrt{(460 + \text{operating } ^\circ\text{F}) / 530}$$

$$f_3 = \sqrt{\text{molecular weight of gas} / 29}$$



Many fittings of various materials and styles are available.