

Introduction to Thermowells

Selection of Thermowells

Materials—The Longevity Factor

In general, the thermowell material to be chosen for an installation is governed mainly by the corrosion conditions the well will face. The high polish given to all stainless and Monel wells provides maximum corrosion resistance.

Occasionally, the primary consideration is one of strength rather than corrosion resistance. For example, a stainless steel well may be required for high pressure water service instead of a brass well which would be satisfactory from a corrosion standpoint. Consult the pressure-temperature ratings given for each well type.

Wells are also available in special grades of stainless steel, Chrome-molybdenum steel, Silicone bronze, Hastelloy B & C, Nickel, Titanium, and Monel. Tantalum jackets are also available.

Connection—The Installation Factor

In these pages, you will find standard bore wells of threaded, flanged (A.S.A. and Van Stone), and socket weld types.

All threaded wells are made in easily welded or brazed materials. This is important for installations requiring seal welding or brazing. The pipe thread provides mechanical strength, and the weld or braze provides the seal.

Flanged wells (other than Van Stone type) consist of a bar stock well which is solidly welded to a top quality flange. Standard construction uses a primary "J" groove weld and a bevel groove secondary weld. The underside weld is machined to produce a clean fillet. This double welded construction eliminates the possibility of crevice corrosion since no open joints are exposed from either inside or outside the installation.

Socket weld wells are simple to install—simply weld them into place. These wells fit A.S.A. standard socket weld couplings or flanges. The resulting installation is clean and tight.

Insertion Length—The Accuracy Factor

The distance from the tip of the well to the underside of the thread or other connection means is the insertion length (designated as "U"). For best accuracy, this length should be great enough to permit the entire temperature-sensitive part of the element to project into the medium being measured. A properly installed element will project into a *liquid* a distance equal to its sensitive length plus at least one inch. In air or gas, the element should be immersed to its sensitive length plus at least three inches.

Thermocouples and thermistors have short sensitive lengths. They can be used with shorter insertion length thermowells.

Bimetal thermometers, resistance thermometers and liquid-in-glass thermometers have sensitive portions between 25 to 51 mm (1 to 2") long. Therefore, the minimum standard insertion length of 64 mm (2½") must be entirely immersed in liquid for proper accuracy.

Filled system thermometer bulbs may have sensitive portions from one to several inches in length. Determine the sensitive length of the bulb before choosing an insertion length.

Above all, be sure that *dead length*, *i.e.*, that required to pass through walls, pipe fittings, etc., is taken into account when choosing the necessary well insertion length.

Bore Size—The Interchangeability Factor

Almost any installation uses several types of temperature measuring sensors. The selection of a standard bore diameter can produce extreme flexibility within the plant. The same well can accommodate either thermocouple, resistance thermometer, bimetal thermometer, or test thermometer.

The bore sizes of wells cover the most commonly used temperature-sensing elements as follows.

7 mm (0.260")
Diameter Bore: Bimetal Thermometers 6 mm (¼") Stem
Thermocouples—(#20 Gage)
Liquid-in-glass Test Thermometers (unarmored)
Other elements having 6 mm (0.250") maximum diameter

10 mm (0.385")
Diameter Bore: Thermocouples (#14 Gage)
Liquid-in-glass Test Thermometers (armored)
Other elements having 9.5 mm (0.35") maximum diameter

Tapered or Straight Wells— The Velocity Rating Factor

Tapered shank wells provide greater stiffness with the same sensitivity. The higher strength-to-weight ratio gives these wells a higher natural frequency than the equivalent length straight-shank wells, thus permitting operation at higher fluid velocity. Refer to "Velocity Ratings of Wells."

Velocity Ratings of Wells

Well failures, in many cases, are not due to the effects of pressure and temperature alone. Inadequate strength of a well can be due to improper choice of wall thickness or material. OMEGA assumes no responsibility for the failure of a thermowell except as stated in the OMEGA warranty found in the front of the Temperature Measurement Handbook.

Less familiar, and more dangerous, are the *vibrational effects* to which wells are subjected. Fluid, flowing by the well, forms a turbulent wake (called the Von Karman Trail) which has a definite frequency based on the diameter of the well and the velocity of the fluid. It is important that the well have sufficient stiffness so that the wake frequency will never equal the natural frequency of the well itself. If the natural frequency of the well were to coincide with the wake frequency, the well would vibrate to destruction and break off in the piping.

Recommended maximum velocity ratings can be found for every standard well length and material cataloged. To reduce the complexity of presenting this information, the ratings given are based on operating temperatures of 540°C (1000°F) for wells made of Carbon Steel (C-1018), A.I.S.I. 304, & A.I.S.I. 316. Values for brass wells are based on 180°C (350°F) operation. Limits for Monel wells are based on 480°C (900°F) service. Slightly higher velocity may be possible at lower temperatures.

Where single values appear in the velocity tables, these may be considered safe for water, steam, air or gas. For shorter insertion lengths, consideration is given to the velocity pressure effect of water flowing at higher velocities. The values in parentheses, therefore, represent safe values for water flow, while the unbracketed values can be used for steam, air, gas and similar density fluids.

It should be pointed out that the values given are intended primarily as a guide. To be safe, check each well with your own calculation.

If you have operating conditions requiring special well designs, our Engineering Staff is available to assist you in all cases. OMEGA assumes no responsibility for the failure of a well except for its repair or replacement. *See OMEGA's Warranty.*

Flanged Thermowells

When ordering FLANGED thermowells, be sure to specify the flange fully. USE A SKETCH or DRAWING OF THE FLANGE and specify FLANGE MATERIAL. FOR BREVITY, USE "SS" for stainless steel, "CS" for carbon steel, "FF" for flat face flanges, and "RF" for raised face flanges.

TO BE SURE THE CORRECT FLANGE IS ORDERED, CONTACT OMEGA'S APPLICATION ENGINEERING DEPARTMENT FOR ASSISTANCE IN ORDERING FLANGED THERMOWELLS.



Industrial Thermowells and Thermocouple Assemblies

OMEGA offers the industrial and research user a complete line of thermocouple assemblies. OMEGA's standard types are listed in this section, which includes a wide selection of component parts, partial assemblies, and complete assemblies ready for installation.

Many other styles of components and assemblies are also available. OMEGA is always glad to quote based on your special needs.

Thermocouple Extension Assemblies

Selection of thermocouple heads is made on the basis of operational requirements, accessibility, and/or the need to avoid direct contact with hot surfaces. Also, it is often required that the extension permit removal of the thermocouple element. For these requirements, OMEGA offers a complete line of configurations and component parts which can be configured for specific applications. OMEGA extensions are made of 1/2" NPT standard weight galvanized steel nipples and unions.



Type 2 Nipple Extension (Ceramic T/C Assemblies Only, See following pages)



A Type 2 assembly is used to connect the head to a thermowell. The length is measured from the bottom of the head to the top of the well. Available assembled in lengths of 0", 13 mm (1/2"), 25.4 mm (1"), 38 mm (1 1/2"), 51 mm (2"), 64 mm (2 1/2"), 76 mm (3"), 102 mm (4"), and 127 mm (5").

Specify: Type 2-(length).

Type 3 Nipple Union Extension (For Thermocouple or RTD Assemblies with 1/2 NPT Fitting)



A Type 3 assembly uses a nipple and a union to connect a head with the male thread of a protection tube or fitting on a ceramic tube. Available assembled in lengths of 89 mm (3 1/2"), 102 mm (4"), 114 mm (4 1/2"), 127 mm (5"), 152 mm (6"), and 178 mm (7").

Specify: Type 3-(length)

Type 4 Nipple Union Nipple Extension (Ceramic T/C Assemblies Only, see following pages)

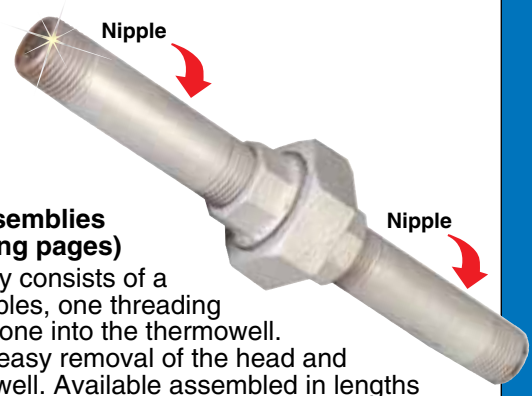

A Type 4 assembly consists of a union and two nipples, one threading into the head and one into the thermowell. This type permits easy removal of the head and element from the well. Available assembled in lengths between 76 mm (3") and 305 mm (12").

Specify: Type 4-(length)

Non-Standard Extensions

Additional cost for each additional 152 mm (6") or fraction thereof up to 1219 mm (48"). Over 1219 mm (48"), please consult the Sales Department.

Head and Well Assemblies

Industrial Protection Head Assembly Probes Inserted into Thermowells

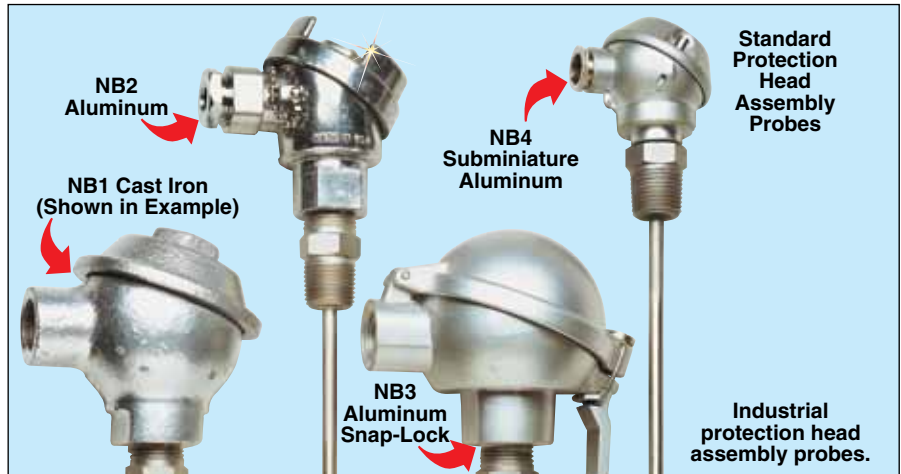
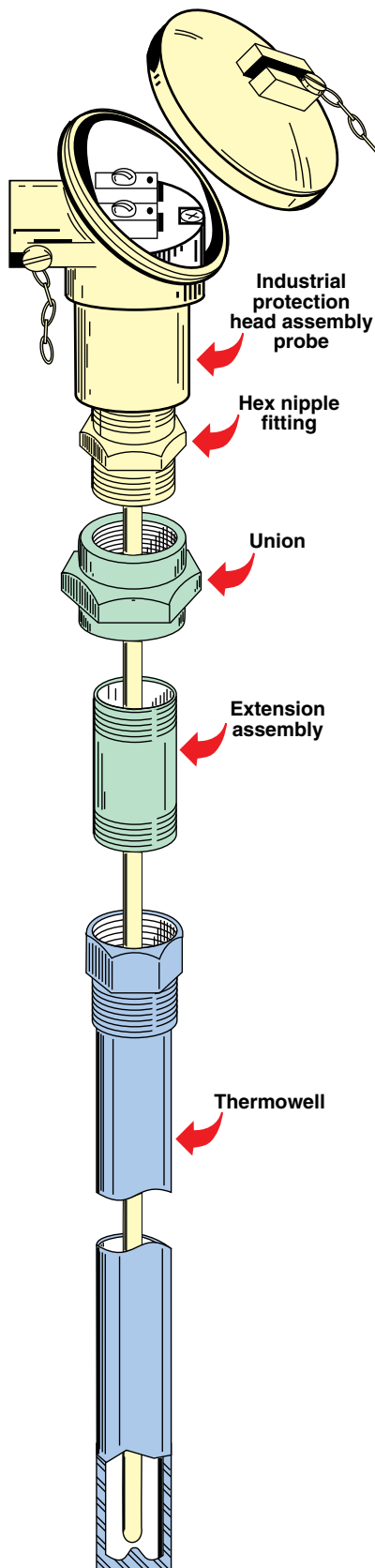

The 1/2 NPT mounting thread allows 1/4" OD industrial protection head assemblies to be put directly into OMEGA® thermowells whose bore is 0.260" without having to use any additional hardware. In this case, the probe length must be the same as the element (stem) length of the desired thermowell.

When an extension assembly is desired, a Type 3 extension assembly can be inserted to separate the protection head from the thermowell. In this case the probe length would be the same as the element length (stem length) of the desired thermowell plus the assembled extension assembly length.

Spring Loaded Assemblies (option for models pictured above)

Using spring loaded industrial protection head assemblies guarantees a positive contact between the sensitive portion of the temperature probe and the bottom of the thermowell, reducing response time. OMEGA also recommends the use of a thermally conductive grease, such as our OT-201, to further aid in reducing response time.

How To Order

Ordering an HWA assembly is easy. Simply follow the model number format below:

Example: HWA / NB1-CASS-14G-12-TBSL / 3-6 / 1/2-260S-U4 1/2-304SS

NB1-CASS-14G-12-TBSL

NB1 cast iron head, thermocouple Type K, 304 SS sheath, 6 mm (1/4") OD, grounded junction, 305 mm (12") length, with spring-loaded terminal block. Thermocouples as well as RTD assemblies with a 6 mm (1/4") diameter can be used. Length should equal the stem (element) length of the desired thermowell plus the assembled length of the Type 3 extension assembly if any. (See thermowell pages, for stem [element] lengths.)

3-6

Type 3 extension assembly; 152 mm (6") long assembled. A Type 3 extension assembly is proper in this configuration. If no extension assembly is needed, do not include the space in the HWA part number.

1/2-260S-U4 1/2-304SS

Standard threaded well for 1/4" element, 1/2" NPT thread, 114 mm (4 1/2") insertion length, 304 SS material. For a complete listing of thermowells, see OMEGA thermowells online for details.

Ceramic Insulated Thermocouple Elements Inserted into Thermowells

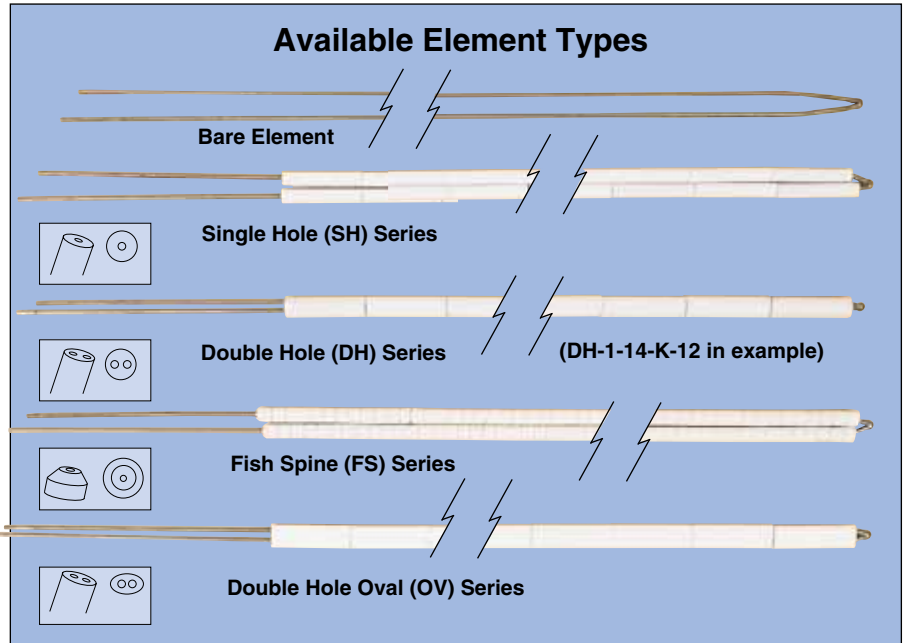
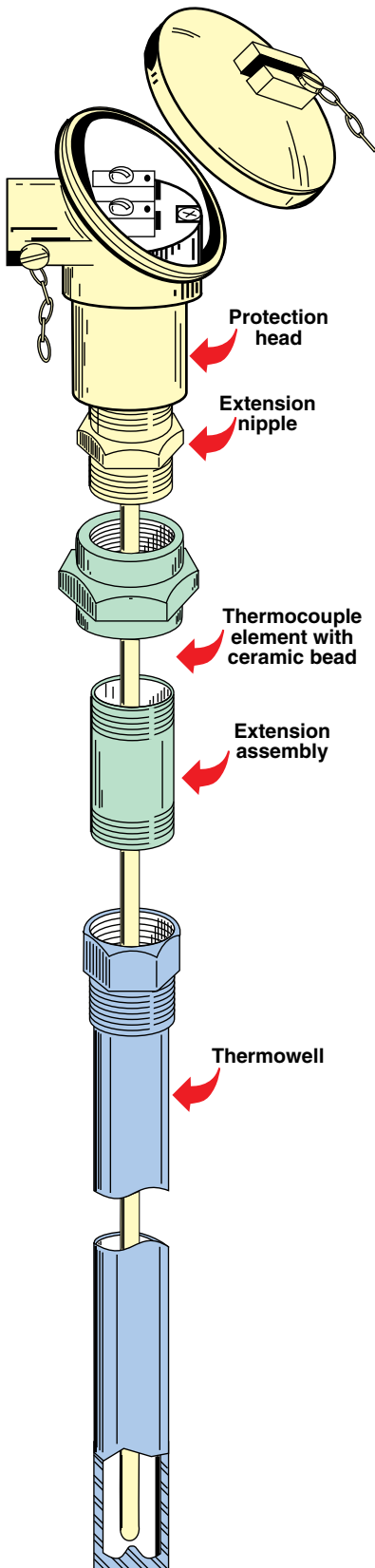

Ceramic insulated thermocouple elements can be used to make HWA assemblies. Here, the protection head is attached to the thermowell with a Type 1 extension assembly. The thermocouple element is housed inside and is wired to the terminal block inside the protection head. Spring loading is not available in this configuration.

A Type 4 extension assembly can also be used in this type of HWA assembly. This nipple-union-nipple extension assembly allows for disassembly of the unit without having to spin the protection head (which may be hooked up to conduit).

How To Order

Follow the format below to order this type of head and well assembly:

Example: HWA / NB1-2 / 4-3 / DH-1-14-K-12 / 1-385H-U4½-304SS

NB1-2

NB1 type cast iron protection head with a 2-position terminal block. See thermocouple head selection guide for a complete listing of available protection heads.

4-3

Type 2 extension assembly; 76 mm (3") long assembled. Either a Type 2 or Type 4 extension assembly can be used with this style HWA. See previous pages for a complete selection of extension assemblies.

DH-1-14-K-12

Double hole ceramic insulated thermocouple element, Type K, 14 AWG, 305 mm (12") length. The length of this thermocouple should be the element (stem) length of the thermowell desired 152 mm (6"), plus the extension assembly length 76 mm (3"), plus 76 mm (3"), for a 305 mm (12") total. (Verify insulator will fit in well.)

1-385H-U4½-304SS

Heavy-duty thermowell, 1" NPT thread, 9.8 mm (0.385") bore for up to 9.5 mm (3/8") diameter elements. 114 mm (4½") insertion length, 152 mm (6") stem/element length. The bore size of the well, 9.8 mm (0.385") in this case, must exceed the outside dimensions of the ceramic insulators.