

# FUSE SIZING GUIDE

## PRACTICAL APPLICATION INFORMATION



This guide is a general recommendation and does not include the many variables that can exist for specific situations such as special local codes, unusual temperature or other operating conditions, N.E.C. demand factors, conductor derating, etc.

### Recommended U.L. Current Limiting Fuse Classes & EDISON Fusegear Symbols:\*

#### Time-Delay Type

Class L	-LCL	-600VAC or less: 601-6000A
Class RK1	-LENRK	-250VAC or less: 6/10-600A
	-LESRK	-600VAC or less: 1/2-600A
Class RK5	-ECNR	-250VAC or less: 1/10-600A
	-ECSR	-600VAC or less: 1/10-600A
Class J	-JDL	-600VAC or less: 1-600A
Class CC	-HCTR	-600VAC or less: 1/4-10A

#### Fast-Acting Type (Non/time-delay)

Class T	-TJN	-300VAC or less: 1-800A
	-TJS	-600VAC or less: 1-800A
Class L	-LCU	-600VAC or less: 601-6000A
Class RK1	-NCLR	-250VAC or less: 1-600A
	-SCLR	-600VAC or less: 1-600A
Class J	-JFL	-600VAC or less: 1-600A
Class CC	-HCLR	-600VAC or less: 1/10-30A

\*The fuse classes shown are U.L. Listed as "current limiting" with 200,000 RMS symmetrical amperes interrupting rating. Classes J and L are not interchangeable with fuses having lower I.R.. Class R fuses require Class R rejection fuse clips to prevent interchangeability with Classes H and K fuses with lower interrupting rating. (N.E.C. 110-9 and 240-60b.)

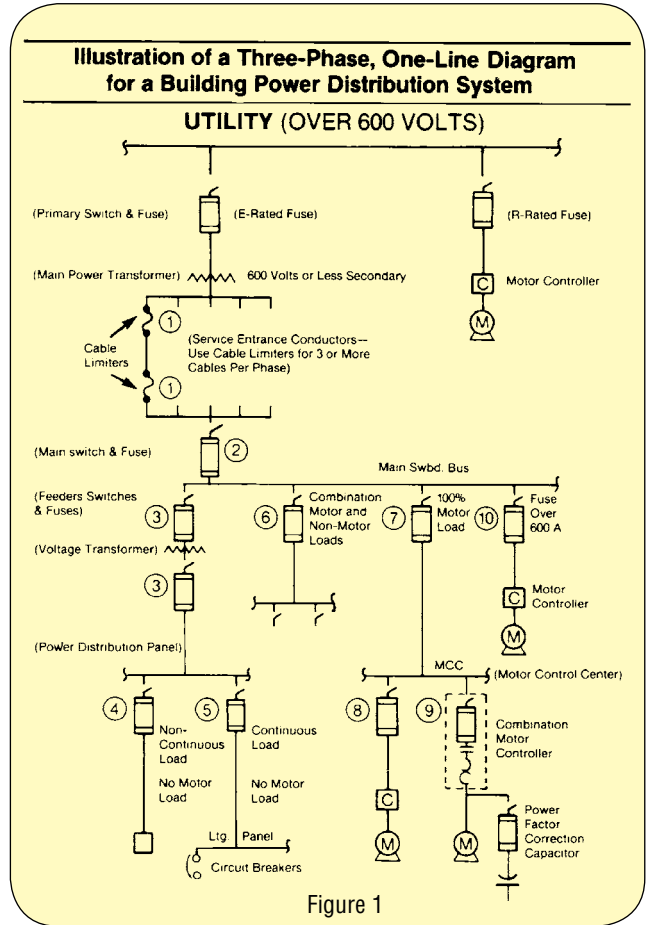

Figure 1

### 1 Main Service Conductor Cable Limiters (N.E.C. 240, 450-6):

a) Select by cable size and mounting terminal configurations required.

### 2 Main Service Circuit Fuses—Mixed Loads:

a) Size fuses same as item 6.

### 3 Transformer Circuit Fuses (N.E.C. 450-3b, 240-3, 240-21, 384-16d, 430-72b Ex. 3, 4 & (c) as required):\*

a) PRIMARY FUSES: Size fuses not over 125%. As exceptions exist, refer to the appropriate N.E.C. paragraphs.

Recommended fuses: LESRK, ECSR, JDL, LCL+.\*

b) SECONDARY FUSES (Sum of following): 125% of the continuous load plus 100% of non-continuous load. Fuse size not to exceed 125% of transformer secondary rated amps. RECOMMENDED FUSES: LENRK, ECNR, NCLR, JDL or LCU.

\*Fuse size must not exceed ampacity of conductors. Where selectivity is desired, refer to EDISON selectivity methods.

### 4 Branch Circuit Fuse Size, No Motor Load (N.E.C. 240-3, 220-3):\*

a) 100% of non-continuous load.

\*Do not exceed conductor ampacity. Recommended fuses: LENRK, ECNR, NCLR, JDL, LCU, or LCL.

### 5 Branch Circuit Fuse Size, No Motor Load (N.E.C. 240-3, -220-3):\*

a) 125% of continuous load. Fuse may be sized 100% when used with a continuous rated switch. Recommended fuses same as 4.

\*Do not exceed conductor ampacity.

### 6 Feeder Circuit Fuse Size, Mixed Load (N.E.C. 220-10b, 240-3, 430-22a Ex. 1, 430-24):\*

- a) 100% of non-continuous, non-motor load plus 125% of continuous, non-motor load
- b) Determine non-continuous motor load (N.E.C. 430-22a EX. Add to "a") above.
- c) Determine A/C or refrigeration load. (N.E.C. 440-3b). Add to "a") above.

d) 150% of the nameplate current rating of the largest continuous-duty motor. Add to "a") above.

e) 125% of the nameplate current rating of other continuous duty motors. Add to "a") above.

f) Recommended fuses: LENRK/LESRK, JDL, ECNR/ ECSR, LCU, LCL.

\*Do not exceed conductor ampacity.

### 7 Feeder Circuit Fuse Size, 100% Motor Load (N.E.C. 240-3, 220-10b, 430-24):\*

a) Determine non-continuous motorload (N.E.C. 430-22a Ex. 1).

b) Determine load of A/C or refrigeration equipment (N.E.C. 440-3, -5, -12). Add to "a") above.

c) 150% of nameplate current rating of the largest continuous duty motor. Add to "a") above.

d) 125% of the other continuous-duty motors. Add to "a") above.

e) Recommended fuses: LENRK/LESRK, JDL, ECNR/ ECSR or LCL.

\*Do not exceed conductor ampacity.

# PRACTICAL APPLICATION INFORMATION

## 8 Branch Circuit Fuse Size, Individual Motor Load, With Fuse Overload Protection (No Starter Overload Relays): (N.E.C. 430-32, 430-36):

a) Motors with 1.15 Service Factor or temperature rise not over 40 Degrees C., size fuses at not more than 125% of the motor nameplate current rating.

b) Best protection is obtained by measuring motor running current and sizing fuses at 125% of measured

current for normal motor operation. Reference to "Average Time/Current Curves" is recommended.

d) Recommended Fuses: LENRK/LESRK, JDL, or ECNR/ECSR .

## 9 Branch Circuit Fuse Size, Individual Motor Load, With Starter Overload Relays (N.E.C. 430-32, 430-52):

a) For "back-up" N.E.C. overload, ground fault and short-circuit protection size the fuses the same as (8 a, b) above, or the next standard size larger.

b) The fuse sizes in a) above may be increased as allowed by NEC references. Generally, dual element fuses should not exceed 175% of motor nameplate F.L.A. and non-U.L. defined time-delay fuses not more than 300%.

c) Recommended fuses: LENRK/LESRK, JDL, ECNR/ECSR or LCL.

## 10 Fuse Sizing for Individual Large Motors With F.L.A. Above 480 Amps or Otherwise Require Class L Fuses - (N.E.C. 430-52):

### Application Tips

1. Size fuses as closely as practical to the ampacity of the protected circuit components without the probability of unnecessary fuse opening from harmless, transient current surges. This usually requires a choice between time-delay and non-time-delay fuses.

2. Use Class R fuse clips with Class R fuses to prevent installation of fuses with less interrupting rating or current limitation. Class H fuse reducers cannot be used with Class R fuse clips.

3. When a conductor is oversized to prevent excess voltage drop, size the fuses for the ampacity of protected circuit components instead of oversizing fuses for the larger conductor.

### Safety

Industry PUBLIC SAFETY standards that apply to overcurrent protection devices (OPD), fuses and circuit breakers, are intended to apply to both types of devices. The use of these devices serves public safety which includes all aspects of fuse or circuit breaker performance and dependability.

Any industry requirements that apply to fuses apply equally to circuit breakers. Industry standards do not intend any deliberate compromises for public safety.

Levels of Government regulations and ordinances, from Federal to local, usually base acceptable safe performance and application of fuses and circuit breakers on the National Electrical Code. The NEC commonly refers proven safe performance to the Standards of Safety of Underwriters Laboratories, Inc. The NEC is sponsored by the National Fire Protection Association.

Therefore, fuses manufactured to meet the same standards of U.L. testing and "Listing" for specific types are physically and electrically interchangeable, based on the standards, regardless of brand.

Fuses can be designed and manufactured to higher standards than the minimum standards required to pass U.L. testing to be "Listed".

*For all of the reasons above, Edison Fuses Inc. manufactures fuses not only to meet industry standards, but also to reach the highest quality standards found in the industry.*

### National Electrical Code

The National Electrical Code (N.E.C.) is sponsored by the National Fire Protection Association. This Code is adopted as the MINIMUM standard for public safety by the federal government, states, counties, cities and many private organizations. Enforcement is usually the responsibility of Professional Electrical Inspectors provided with enforcement authority.

### Fuse Ratings

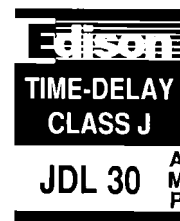

Fuses with an A-C voltage rating may be applied at system voltages below the fuse voltage rating, but not at voltages above the fuse voltage rating. The other A-C fuse ratings remain the same at applied voltages below the fuse voltage rating.

A-C rated fuses should not be applied in D-C voltage circuits unless D-C application ratings are provided by the fuse manufacturer. Except for some special purpose fuses, D-C ratings are not usually shown on fuse labels.

EDISON Time/Current Curves, Peak Let-Through Curves are based on 60 Hertz A-C data.

The operating frequency (Hertz) will affect fuse characteristics in various ways.

Time/Current Curves will not shift and fuse ratings will not change from 1-100 Hertz in normal applications. If ferrous hardware is used to mount the fuses, eddy current heating could alter the ratings.

Above 100 Hertz, "skin effect" could alter the fuses' rating characteristics. This effect must be analyzed on an individual application basis.

# PRACTICAL APPLICATION INFORMATION

## FUSE RATINGS, CONT.

Other characteristics shown on fuse labels such as “interrupting rating”, “current limiting”, “time-delay”, “fast-acting” and Underwriters Laboratories, Inc. (U.L.) Class are described elsewhere.

Fuse labels show “certification” or “listing” logo’s when applicable. Such logo’s may be:

- “U.L.” (U.L. “Listed”)
- “CSA” (Canadian Standards Association “certified”)
-  (U.L. Recognized)

Such logos mean that the fuse meets the performance standards of these safety organizations.

Some EDISON fuses, such as rectifier protection fuses, special purpose fuses, etc., do not show safety organization logos because test standards do not exist, or logo’s are awaiting testing for newly established standards. In these cases, any necessary additional information may be obtained from the manufacturer.

## Ambient Fuse De-Rating...

Fuses designed to U.S.A. standards are tested for proper ampere ratings at 25 degrees Centigrade. Since fuses operate by heat melting fuse elements, the ampere ratings can change for higher or lower ambient temperature (temperature of air around an enclosure in which fuses are installed). The following information is provided to choose fuses with different ampere ratings for unusually high or low ambient temperatures.

## Correction Factors for Edison Dual-Element ECNR/ECNR and LENRK/LESRK Fuses<sup>(1)</sup> (See next column)

Ambient Temperatures		Carrying Capacity of Fuse in % of Rating	% of Opening time
°C	°F		
-60	-76	120	135
-40	-40	117	130
-20	- 4	113	125
0	32	108	120
20	68*	103*	105
25	77*	100*	100
30	86*	98*	95
40	104*	95*	85
60	140	85	70
80	176	75	50
100	212	60	35

\*No correction needed with this range.

## Correction Factors for Edison Fast-Acting and Non-Delay Fuses<sup>(1)</sup>

Ambient Celsius Temperatures	Maximum Load Current (% of Rating)
-20 to -40	93%
-19 to -1	90%
zero to 24	86%
25 to 60	80%
61 to 80	60%
81 to 100	45%

<sup>(1)</sup>Fuses installed in an enclosure with a base loading of 80% as required by the National Electrical Code. Contact Edison Fuses Inc. for other conditions.

## Interrupting Rating (I.R.)

N.E.C. 110-9 requires that the interrupting rating of fuses and breakers not be less than the maximum available short circuit current at their point-of-application as indicated by Figure 2. Circuits where fuses and breakers are installed may be capable of thousands of amperes of short circuit current flow during a short circuit condition. When fuses or breakers are installed where the value of short circuit current flow may exceed the interrupting rating of the devices, a very serious safety hazard may exist. A flow of short circuit current in excess of the device interrupting rating may cause only a mild device rupture during device opening or a violent explosion depending on the value of excess short circuit current flow.

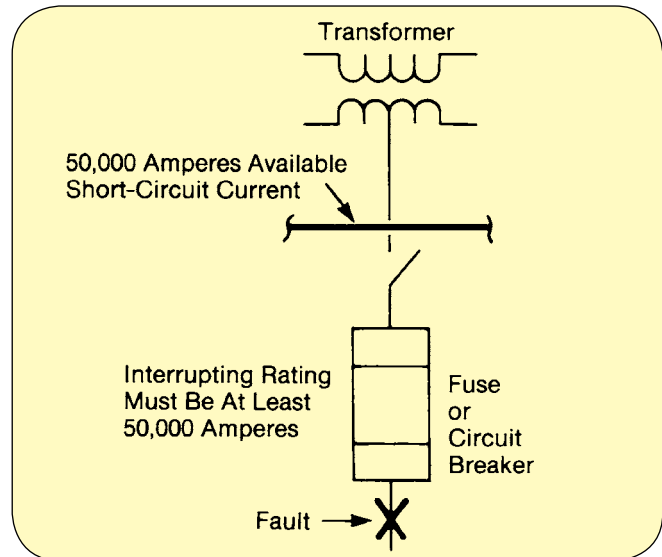

Figure 2

## Overcurrent

The term “overcurrent” refers to abnormal current flow higher than the normal value of current flow in an electrical circuit. Uncorrected “overcurrent” can cause serious safety hazards and costly damage to electrical equipment and property.

# PRACTICAL APPLICATION INFORMATION

## OVERCURRENT, CONT.

Fuses and most circuit breakers are installed in electrical circuits to open and stop the flow of “overcurrent”.

Fuses and typical circuit breakers respond and open for both low and high values of overcurrent flow. “Limiters” and “magnetic only” circuit breakers respond only to high values of overcurrent flow.

There are three basic types of current flow in an electrical circuit:

1. Normal intended current flow to operate electrical equipment.
2. Abnormal overcurrent flow with a value of up to 10 times normal current flow. This is known as an “overload”.
3. Abnormal overcurrent flow with a value more than 10 times the normal current flow is known as “short-circuit” or “fault” current flow.

Unless otherwise noted, current (amperes) and voltage (volts) are alternating current/voltage RMS values as read on an ammeter or voltmeter. The alternating frequency is 60 HZ (cycles per second). Impedance is a combination of resistance and inductive reactance and is expressed in units of ohms.

## Overcurrent Protection Device Symbols...

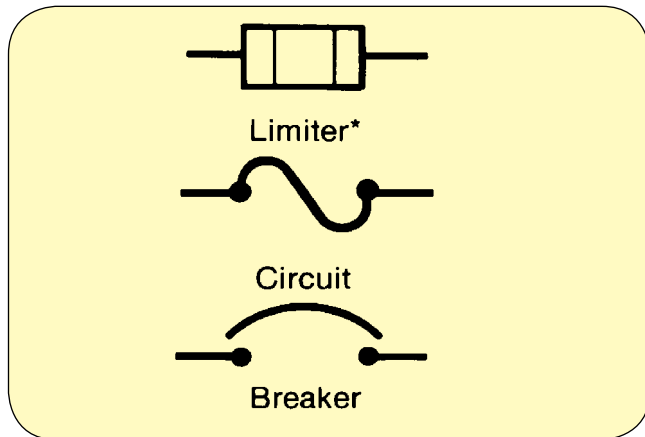

Ohm's Law is used to find the value of **normal** current flow in the simple circuit illustration. (See Figure 3)

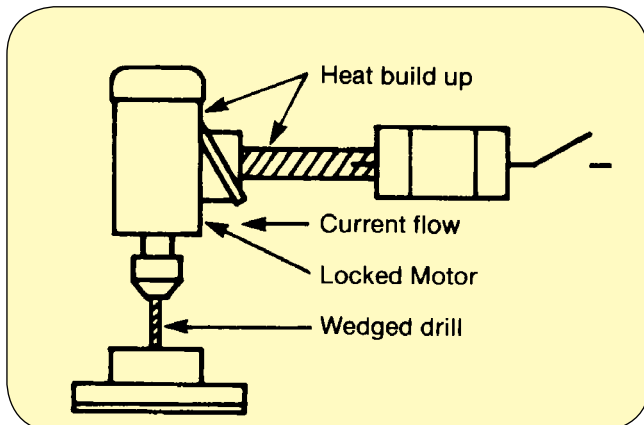

Figure 3

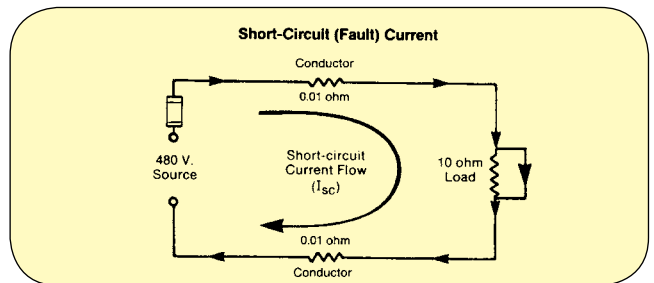
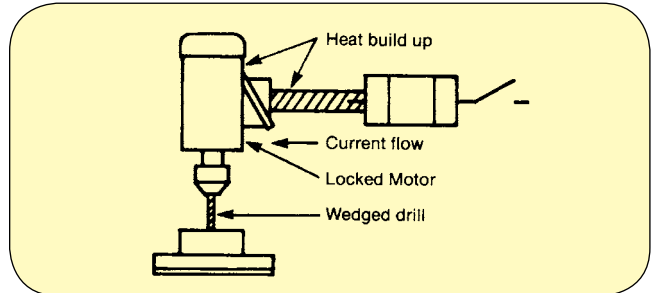

Figure 4

Figure 4 is identical to Figure 3 except a short-circuit fault has been shown that by-passes the impedance of the load of 10 ohms. The only impedance remaining to oppose the flow of current is 0.02 ohms which is the total impedance of the conductors. Short-circuit current now flows around the load as shown by the arrow in the heavy line.

The value of **short-circuit current** flow for this simple illustration is determined by using Ohm's Law:

$$I_{SC} = \frac{\text{VOLTS}}{\text{TOTAL OHMS}}$$

$$I_{SC} = \frac{480}{0.02} = 24,000 \text{ amperes}$$

There are many specific ways that short-circuits (faults) may occur. Some of the more common are accidents, carelessness in the misuse of “fish tape”, tools, etc., crossed phases, contamination,

# PRACTICAL APPLICATION INFORMATION

## Overcurrent Protection Devices...Fuses and Circuit Breakers

**Fuses** contain an element that acts like a conductor for the normal current flow. The element's ability to sense abnormal current is the basis for the amp rating of the fuse. When an overcurrent develops that exceeds the fuse rating, heat builds up inside the fuse and melts or "opens" the element. Once the element is melted and the arc extinguished, current flow stops.

When the overload or fault condition that caused the fuse to open is corrected, a proper replacement fuse restores the original dependable protection.

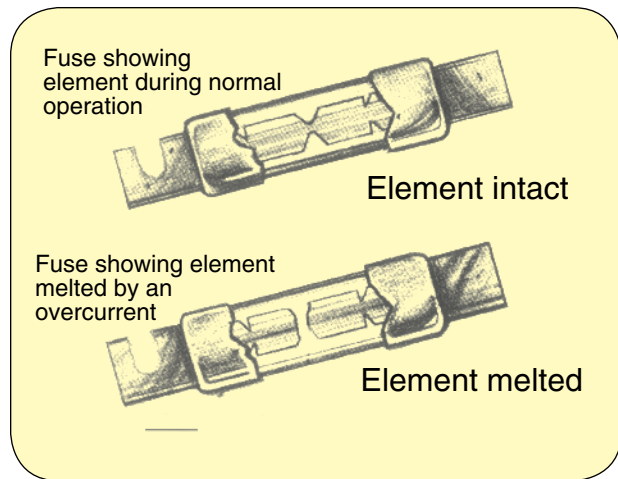

**Circuit Breakers** contain a resettable latch which acts like an "ON-OFF" switch for the normal current flow. When abnormal current flows through the circuit breaker, the latch trips, and the indicator on the outside of the circuit breaker moves into the "OFF" position. Once the overcurrent problem has been corrected, the indicator lever can be reset into the "ON" position, which simultaneously resets the latch inside the circuit breaker.

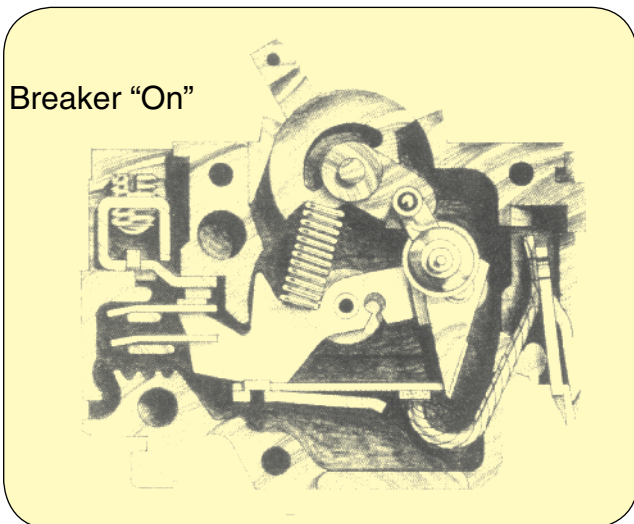

Breaker "Off"

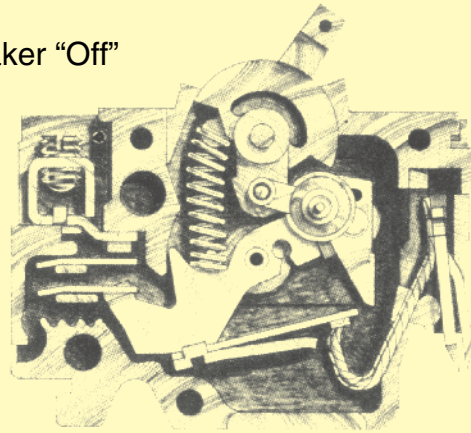

## Summary

It is obviously necessary to rate fuses and circuit breakers according to their ability to safely interrupt a given MAXIMUM value of short-circuit current flow.

Standard U.L. Fuse Interrupting Ratings*	
Class H	10,000
Class K	50,000, 100,000 or 200,000
Classes J, L, R, T, and CC	200,000
Class G	100,000

Standard U.L. Circuit Breaker Interrupting Ratings*	
5,000	42,000
7,500	50,000
10,000	65,000
14,000	85,000
18,000	100,000
22,000	125,000
25,000	150,000
30,000	200,000
35,000	

\*Contact manufacturer for availability of ratings.

Figure 5

A specific fuse or breaker may be submitted for testing at one of the standard levels shown in Figure 5. The successful product testing results in "listing" of the product as having an "interrupting rating" (I.R.) at the level of test current. In other words, when a fuse or circuit breaker will safely interrupt developed energy at a specific value of short-circuit current, say 200,000  $I_{rms}$ , the product manufacturer may place a UL logo and words similar to "Interrupting Rating 200,000 Amps A-C" on the product label. The product will interrupt any value of fault current up to 200,000  $I_{rms}$  MAXIMUM.

When fuses and circuit breakers are properly applied within their interrupting rating, as required by N.E.C. 110-9, device opening during short-circuit current flow generates high levels of energy inside the devices.

# PRACTICAL APPLICATION INFORMATION

EDISON current limiting fuses are designed to retain their high interrupting rating in normal use until caused to open and are then replaced with a new fuse.

## Magnitude of Available Short-Circuit Current

Figure 6 shows maximum values of available short-circuit current at the secondary terminals of some typical sizes of building main service transformers. Note, the increased values of amperes when three single-phase transformers are connected for three-phase operation. For this situation, the percent internal impedance (%Z) of the three transformers must be matched. The three-phase %Z is the same as for one of the single transformers.

Transformer KVA Size	System Voltage		
	Single-Phase 120/240V	Three-Phase 120/208V	Three-Phase 277/480V
37-1/2	18,000 A.		
50	22,000 A.		
100	44,000 A.	18,000 A.	8,000 A.
250	82,000 A.	40,000 A.	18,000 A.
333	98,000 A.		
500	184,000 A.	82,000 A.	35,000 A.
750	–	42,000 A.	18,000 A.
750*	–	122,000 A.	53,000 A.
1000	–	56,000 A.	24,000 A.
1000*	–	132,000 A.	57,000 A.

\*Three-single-phase transformers.

Figure 6

The following equation was used to calculate Figure 6 values:

$$I = \frac{100\%}{\%Z} \times \text{Transformer secondary full load amps}$$

Refer to Table Z page Z-124 for typical lowest transformer percent impedance (%Z) used to find short circuit values.

Many congested commercial building areas have underground low voltage network systems for multiple building service connections. Available fault current may approach 200,000  $I_{rms}$ .

The fault current values will be reduced by utility KVA capability and impedance in a power distribution system.

## Symmetrical and Asymmetrical Short-Circuit Current

When correctly selected overcurrent protection devices are used there is no practical reason for an electrical power system designer to be concerned about values of asymmetrical short-circuit amperes available unless there is reason to believe that a system has a ratio of inductive reactance to resistance higher than U.L. test values for equipment short circuit ratings, circuit breaker or current limiting fuses interrupting ratings

Current limiting fuse manufacturers typically test directly across a fuse at 460,000 peak asymmetrical amperes for a U.L. interrupting rating listing at 200,000 RMS symmetrical amperes. A designer may want to refer to U.L. Standard 489 for testing of molded case circuit breakers..

It may be confusing that most industry references to short-circuit current and short-circuit ratings are in “RMS symmetrical amperes” ( $I_{rms}$ ), but this is for convenience and common understanding that the “worse case” requirements imposed by “asymmetrical” values are “built-in” for U.L. testing.

Figure 7 shows the relationship between two cycles of symmetrical and asymmetrical current at the typical “worst case” power system Asymmetry Factor of 2.3. When considering that current limiting fuses, in sizes 3000A or less, will interrupt the current shown in Figure 7 before the peak of the first one-half cycle, this subject is of little value unless non-limiting devices are specified.

## Fuse Current Limitation

Refer to Figure 8 for a description of fuse current limitation. The LENRK 600 fuse limitation indicated by the small hatched area is compared to two cycles of fault current flow as indicated by the dashed line.

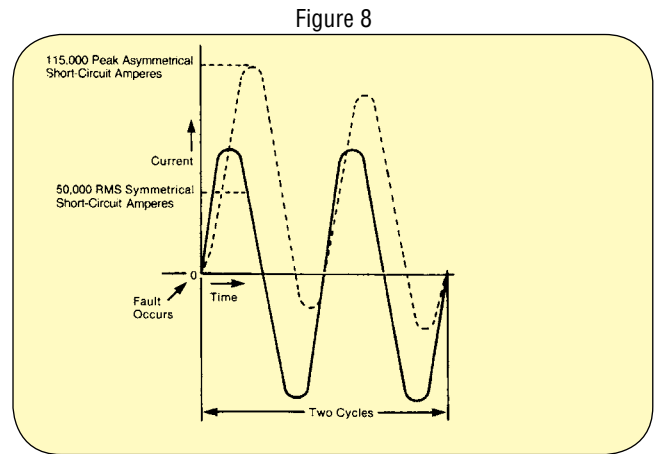
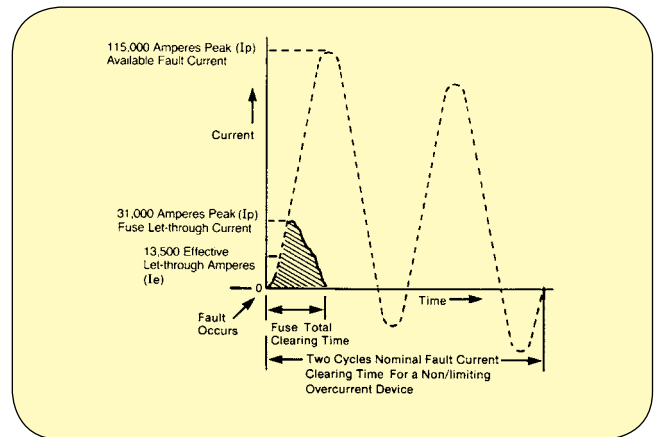

Figure 7



Short-Circuit Protection Comparison of EDISON LENRK 600 Current Limiting Fuses vs. Non/Limiting Overcurrent Protection Devices with 50,000 RMS Amperes Short-Circuit Current Available.

# PRACTICAL APPLICATION INFORMATION

## FUSE CURRENT LIMITATION, CONT.

Fault current flow through conducting paths to a fault location produces two major potentially damaging effects to equipment, components and conductors:

a) Magnetic fields between conductors produce magnetic stress (physical force). Physical bracing is required with the extent (cost) dependent on the magnitude of fault current allowed to flow. Force varies directly with the square of the maximum peak ( $I_p$ ) current during the first one-half cycle.

b) Fault current flow causes thermal stress (excess heat) in conducting paths dependent on the magnitude of RMS ( $I_{rms}$ ) or effective ( $I_e$ ) current squared multiplied by the time of current flow ( $I^2t$ ).

In the Figure 8 (see page Z-111) illustration, the LENRK 600 fuses reduce the physical magnetic force between conductors to about 8% of that allowed by a non-limiting device.

The LENRK 600 fuses reduce  $I^2t$  thermal stress reference over 14,500% less than allowed by a non-limiting device.

Any potentially damaging arcing at the fault location will also be reduced.

Specifying EDISON current limiting fuses provides excellent protection by reducing short-circuit current energy allowed to flow to a fault. Thus, the requirements of NEC 110-10 and 240-1 can be met.

U.L. provides a service to equipment manufacturers for listing short-circuit current ratings at any of the optional maximum values shown in Figure 9.

This provides a means for power system designers to specify minimum short-circuit ratings to meet N.E.C. 110-10.

## U.L. Short-Circuit Ratings for Electrical Equipment

The term "Equipment" includes switchboards, panelboards, motor control centers, busway and motor controllers.

Standard U.L. Equipment Short-Circuit Current Ratings in RMS Amperes*	
14,000	65,000
18,000	75,000
22,000	85,000
25,000	100,000
30,000	125,000
35,000	150,000
42,000	200,000
50,000	

\*Contact manufacturer for availability of ratings.

Figure 9

## Maximum Allowable U.L. Let-Through Values for Fuses at 100,000 RMS Symmetrical Amperes\*

U.L. Fuse Class	Fuse Rating, Amperes	U.L. Let-Through	
		$I_p \times 10^3$	$I^2t \times 10^3$
CC	30	6	5
J	30	7.5	7
	60	10	30
	100	14	80
	200	20	300
	400	30	1,100
RK1	600	45	2,500
	30	10	10
	60	12	40
	100	16	100
	200	22	400
RK5	400	35	1,200
	600	50	3,000
	30	11	50
	60	21	200
	100	25	500
L	200	40	1,600
	400	60	5,000
	600	80	10,000
	800	80	10,000
	1200	80	12,000
L	1600	100	22,000
	2000	120	35,000
	2500	165	75,000
	3000	175	100,000
	4000	220	150,000
	5000	–	350,000
	6000	–	350,000

\*U.L. tests current limiting fuses at 50,000, 100,000 and 200,000 RMS symmetrical amperes.

Figure 10

U.L. testing and listing of equipment protected by current limiting fuses is done with fuses that have the same current limiting performance as the maximum allowable peak let-through current when any fuse manufacturer submits current limiting fuses for testing and listing. The result is that any brand of U.L. listed fuses may be used to protect U.L. short-circuit rated equipment within the specified limit of short-circuit rating.

# PRACTICAL APPLICATION INFORMATION

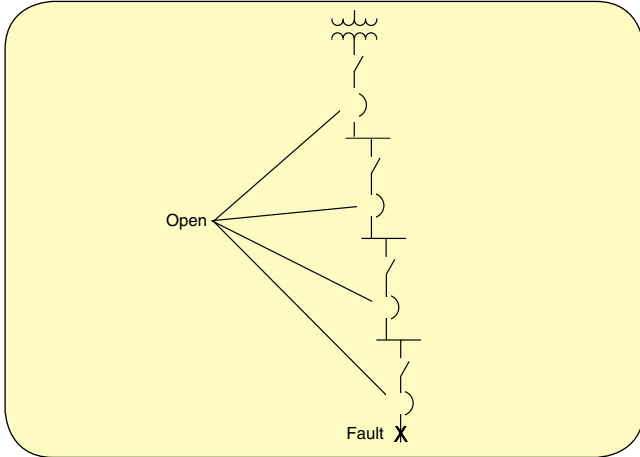

Figure 11

## Selectivity

A non-selectively designed system of overcurrent protection devices is shown in Figure 11. When a building power distribution system is designed without selectivity, potential safety hazards and costly power outages may result. A system with designed selectivity will assure that only the overcurrent protection device for a faulted circuit will open to limit a power outage to the faulted circuit.

Refer to Figure 12 for an illustration of the use of “ $I^2t$ ” to determine fuse selectivity for short-circuit conditions.

Energy from fault current flow builds up heat inside fuses, breakers and conductors as the current flows to a fault location in a system.

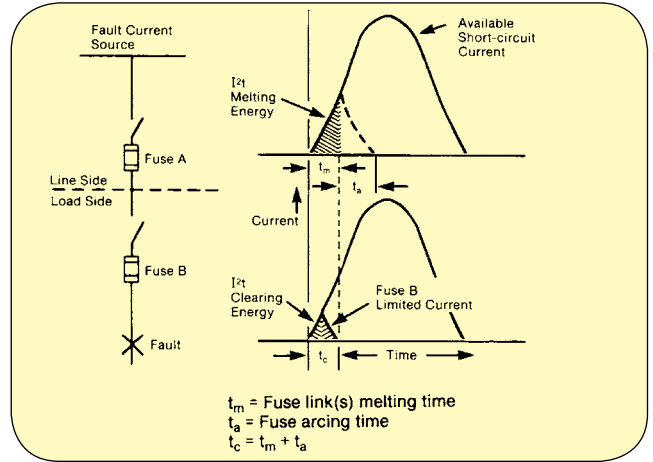

Figure 12

“ $I^2t$  Melting Energy” is a reference to the value of “ $I^2t$  Energy” required to melt the link(s) of Fuse A. “ $I^2t$ ” is not an energy value, but a convenient reference used for comparison purposes. Actual energy would be “ $I^2Rt$ ” where “ $R$ ” is resistance. The value of resistance is so low compared to the other two values that it is ignored for convenience.

“ $I^2t$  Clearing Energy” is a reference to the amount of energy that Fuse B allows to build up in the form of heat during Fuse B “Total Clearing Time.”

Figure 12 shows an obvious conclusion that if the “ $I^2t$  Clearing Energy” of Fuse B is less than the “ $I^2t$  Melting Energy” of the link(s) of Fuse A then Fuse A will not open when a fault on the load side of Fuse B occurs.

## “Selectivity Ratio Guide” For Current Limiting Fuses\*

Divide the amps rating of a load-side fuse into the amps rating of the line-side fuse. If the ratio is “Equal to or larger than” the table ratio, then a fault on the load side of the load-side fuse will cause the load-side fuse ONLY to open to provide selectivity.

Circuit		Load-Side Fuse																	
Current Rating		601-6000A				0-600A		601-6000A		0-600A		0-1200A		0-600A		0-60A			
Type		Time-Delay		Dual-Element Time-Delay		Fast-Acting		Fast-Acting		Fast-Acting		Fast-Acting		Fast-Acting		Time-Delay			
Class		L		RK1		J**		RK5		L		RK1		T		J		G	
Edison Symbol		LCL		LENRK LESRK		JDL		ECNR ECSR		LCU		NCLR SCLR		TJN TJS		JFL		SEC	
Line-Side Fuse	601 to 6000A	Time-Delay	L	LCL	2:1	2:1	2:1	4:1	2:1	2:1	2:1	2:1	2:1	2:1	2:1	2:1	2:1	2:1	N/A
	RK1		LENRK LESRK	–	2:1	2:1	8:1	–	3:1	3:1	3:1	3:1	3:1	3:1	3:1	3:1	4:1		
	0 to 600A	Dual Element	J	JDL**	–	2:1	2:1	8:1	–	3:1	3:1	3:1	3:1	3:1	3:1	3:1	3:1	4:1	
	RK5		ECNR ECSR	–	1.5:1	1.5:1	2:1	–	1.5:1	1.5:1	1.5:1	1.5:1	1.5:1	1.5:1	1.5:1	1.5:1	1.5:1		
	601 to 6000A	Fast-Acting	L	LCU	2:1	2:1	2:1	6:1	2:1	2:1	2:1	2:1	2:1	2:1	2:1	2:1	2:1	2:1	N/A
	0 to 600A		RK1	NCLR SCLR	–	3:1	3:1	8:1	–	3:1	3:1	3:1	3:1	3:1	3:1	3:1	3:1	4:1	
	0 to 1200A		T	TJN TJS	–	3:1	3:1	8:1	–	3:1	3:1	3:1	3:1	3:1	3:1	3:1	3:1	4:1	
	0 to 600A		J	JFL	–	2:1	2:1	8:1	–	3:1	3:1	3:1	3:1	3:1	3:1	3:1	3:1	4:1	
	0 to 60A	Time-Delay	G	SEC	–	3:1	3:1	4:1	–	2:1	2:1	2:1	2:1	2:1	2:1	2:1	2:1	2:1	

**Note:** At some values of fault current, specified ratios may be lowered to permit closer fuse sizing. Plot fuse curves or consult with Edison Fusegear.

\*\*General Notes: Ratios given in this Table apply only to Edison fuses. When fuses are within the same case size, consult Edison Fusegear.

\*Consult Edison Fusegear for latest data.



# PRACTICAL APPLICATION INFORMATION

## Cable Limiter Application

Cable Limiters have internal construction like fast-acting, current limiting fuses and have 200,000 A.I.R. **Unlike fuses, Cable Limiters are designed to provide short-circuit protection only.** The lack of typical fuse overload characteristics is desirable for the intended applications. “Average Time/Current Curves” and “Current Limitation Curves” are available.

The most common applications are for multiple cables connected between a main transformer secondary and a single building load or to several individual building loads. (Figure 1 see page Z-106). Cable Limiters provide short-circuit protection for each cable. The benefits are: (1) Prevention of extensive damage; (2) Isolation of a faulted cable to prevent a total power outage; (3) Reduction of the potential for extensive costs resulting from damage and losses from power outages. Electric utilities commonly apply Cable Limiters in large power distribution networks to reduce the potential for widespread power outage and for cables that serve several individual building services from one transformer.

Unlike fuses which are sized based on current, cable limiters are sized relative to the size of the cable. They are available for a wide range of cable sizes and mounting terminations in voltage ratings of 250 volts AC or less and 600 volts AC or less.

## Application Considerations

### A. Multiple-Cable-Per-Phase

The Figure 1, (see page Z-106) one-line diagram shows an illustration of paralleled cables in one phase of a three-phase system. The first cable limiter will open to isolate the faulted cable allowing power service to continue uninterrupted. It is necessary to oversize cables so that the loss of one will not cause overloading of the remaining cables.

Normally, multiple-cables-per-phase installations have a cable limiter at each end of each conductor.

A phase-to-phase or a three-phase cable fault may cause the isolation of one cable in two or all three phases. This is acceptable for the intended application of Cable Limiters.

When Cable Limiters are applied for two-cables-per-phase, limiters are usually installed at the “line end” of each cable only—since both limiters will open for a fault in one cable. An undesirable phase power outage occurs, but the limiters are intended to reduce potential extensive damage and the time/cost of repair. For three or more cables-per-phase, only line-to-ground faulted cables are expected to be isolated.

During scheduled routine power outages for normal system maintenance, Cable Limiters are checked for opening to indicate a cable fault that needs to be repaired.

Cable Limiters are usually selective with both utility transformer primary overcurrent protection devices and building main devices. However, it is a good practice to check selectivity.

### B. Multiple Cables for Individual Loads

For multiple cables a line-to-ground fault will open a single Cable Limiter so that power is maintained to the remaining services. Damage is minimized, power revenue continues, maintenance time is reduced and customer agitation is minimized.

#### Application Tips:

Copper cable limiters should only be used with copper cable and aluminum cable limiters with aluminum cable.

Cable Limiters with hollow tube crimp terminations require the use of correct crimp die sizes. Die size information for common tool brands is provided with EDISON Limiters.

Heat shrinkable insulation tubing OR (not both together) blown limiter indicators for Limiter installation is available. Contact your EDISON Distributor.

When analyzing Cable Limiter performance, keep in mind that fault current divides in parallel paths.

EDISON high quality Cable Limiters provide designers with a low cost means of improving the safety, performance and practicality of an all-EDISON protected system.

## Class L Fuse Application

### Selecting Fuse Type and Size

Class L fuses are commonly installed in “bolted-pressure contact” switches in switch ratings 800 amperes and larger. Switches are usually installed with the capability of 100% continuous duty per U.L. 977 temperature limits. These switches are usually U.L. listed for 200,000 RMS symmetrical amperes ( $I_{rms}$ ) short-circuit rating.

The specification of EDISON LCU fast-acting fuses is recommended whenever it is suitable to benefit from superior current limitation. For any Class L fuse application it is a good engineering practice to select and size fuses for consideration of the transient motor starting current portion of a mixed load. This practice will reduce the possibility of fuse opening for normal system operation without excessive fuse oversizing.

Fuse Symbol <sup>(1)</sup>	Fuse Amps Rating	Percent Motor F.L.A.*
LCU	800	35%
LCL	800	50%
LCU	1200	50%
LCL	1200	55%
LCU	1600	60%
LCL	1600	60%
LCU	2000	60%
LCL	2000	65%
LCU	3000	60%
LCL	3000	65%

<sup>(1)</sup>LCU fast-acting; LCL time-delay.

\*Percent of total mixed load.

Figure 15

# PRACTICAL APPLICATION INFORMATION

## CLASS L FUSE APPLICATION, CONT.

Figure 15 (see page Z-114) is a guide for maximum motor Full Load Amps percentage of a 100% mixed load on the fuses shown to provide an 8 seconds or more delay to allow all motors to start at the same time. Reduced fuse loading and/or the load operation diversity factor will increase the fuse operation time. Non-typical load/system operation may reduce the fuse operation time.

To determine the operating time of any LCU or LCL fuse with mixed load use the following equation. (Apply load diversity, if any, before using the equation). This equation was used to find Figure 15 (see page Z-114) motor load percentages for the fuse operating time indicated.

$$I_{TL} = [(MT \times 6) + (FT - MT)] 1.1$$

Where:  $I_{TL}$  = Total fuse motor and non-motor load.

$M_T$  = Motor total F.L.A..

$F_T$  = Fuse total mixed load.

1.1 = Tolerance factor.

Refer to a LCU or LCL “Average Time/Current Curves” to find the fuse operating time using “ $I_{TL}$ ” amperes.

EDISON LCL time-delay fuses are recommended ahead of 100% motor loads, either a group of motors or a large individual motor circuit. When the starting diversity of a group of motors or the time/current starting characteristics of a large individual motor are not known, an estimate can be made by multiplying either the total motor nameplate current of a group or nameplate current of an individual motor by 1.5 to determine fuse sizing. Unusual motor operating conditions may require larger fuses.

### Application for UL Equipment Short-Circuit Current Ratings

EDISON LCU and LCL Class L fuses provide excellent short circuit protection while providing electrical power system designers an opportunity to reduce cost and obtain engineered protection.

For example, Figure 1 (see page Z-106) motor control center (MCC) requires a U.L. marked Irms short-circuit current rating “equal to or greater than” the maximum available fault current calculated.

The designer has a choice to reduce the MCC short-circuit rating and cost because of the current limiting ability of EDISON fuses. Refer to Figure 16.

To interpret Figure 16, first locate the MCC available Irms short-circuit current of 31,000 amperes (maximum calculated) on the horizontal current scale. From that point follow the dashed reference lines back to the same scale and read a value of about 16,000 “effective let-through amperes” ( $I_e$ ). The MCC Irms U.L. short-circuit rating may be specified to be no less than 22,000 Irms, which is the next standard U.L. rating above 16,000  $I_e$ .

### Application for Transformer Circuits

Specify EDISON time-delay type fuses ONLY for 600 volts or less transformer primary circuits AND select an adequate fuse delay to prevent unnecessary fuse opening. When specific transformer effective magnetizing inrush amperes and duration are known, refer to an “Average Time/Current Curves” to select fuse amps rating. When this information is not available, an estimate can be made by selecting a fuse delay 0.1 second or longer at a current 12 times the transformer primary full load amperes from the appropriate curve

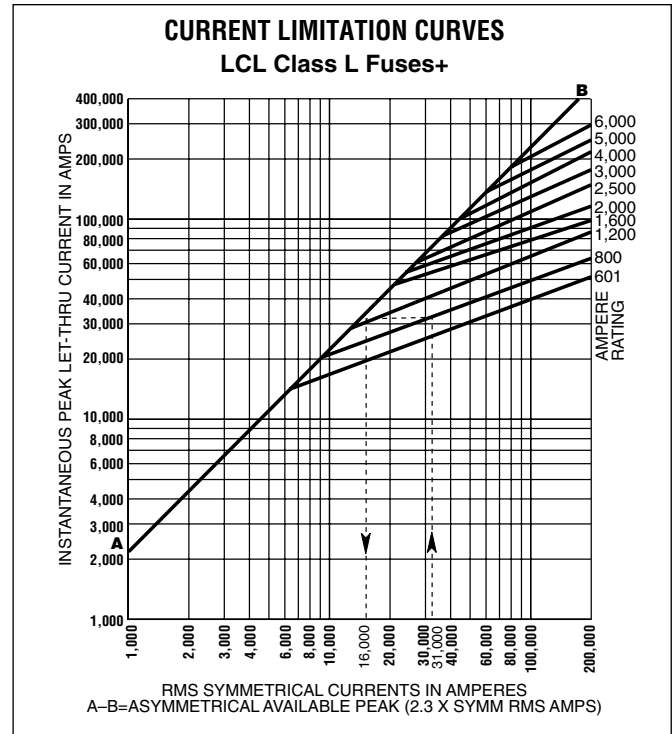

+Contact Edison Fusegear for latest data.

Figure 16

mentioned above. The National Electrical Code allows the use of either time-delay or fast acting (non-delay) fuses for both sides of a transformer with a primary rating 600 volts or less. Check Code requirements for all applications, but it is generally always best to use EDISON dual-element fuses in the primary circuit sized as indicated on page A1. Secondary fuse types may be selected for the type load (inductive or non-inductive) but a practical “rule of thumb” is to use dual-element type fuses whenever possible.

The sizing recommendation above is normal recommendation. Check the inrush characteristics of the transformer being installed to insure proper application.

### Class R (RK) Fuse Application

There is occasional, understandable confusion about designing, specifying and using Class R (RK) fuses. This is usually because of the availability of three distinctly different performance fuses that are physically interchangeable.

The three types are:

LENRK/LESRK Class RK1, dual element, time-delay.

NCLR/SCLR Class RK1, fast-acting (no inherent delay).

ECNR/ECSR Class RK5, dual-element, time-delay.

### Current Limitation Comparison

Figure 17 (see page Z-116) shows comparison of a Class RK1 time-delay fuse (LESRK 200) and a Class RK5 time-delay fuse (ECSR 200). The curve for a Class RK1 fast-acting fuse (SCLR 200) is not shown because the curve almost duplicates the LESRK 200 curve.

The interpretation of Figure 17 (see page Z-116) is the same as for the Figure 16. Note the value of the LESRK 200 fuse (Class RK1, time-delay)  $I_e$  is about 5,700 and the value for the ECSR 200 fuse (Class RK5, time-delay) is about 9,500. For the same fault current the  $I_e$  for a SCLR 200 fuse (Class RK1, fast-acting) is about 5,500.

# PRACTICAL APPLICATION INFORMATION

## CURRENT LIMITATION COMPARISON, CONT.

The RK1 fuses shown have a current limitation advantage of up to 40% over the RK5 fuse. This percentage will vary for different fuse amps ratings. The current limitation of Class RK1 fast-acting fuses (NCLR/SCLR) is somewhat greater in all sizes than Class RK1 time-delay fuses (LENRK/LESRK).

“Peak Let-Through Amps” ( $I_p$ ) of current limiting fuses is sometimes of concern for typical power system design. Reference to this value is helpful to compare the protection ability of mechanical, non-limiting devices.

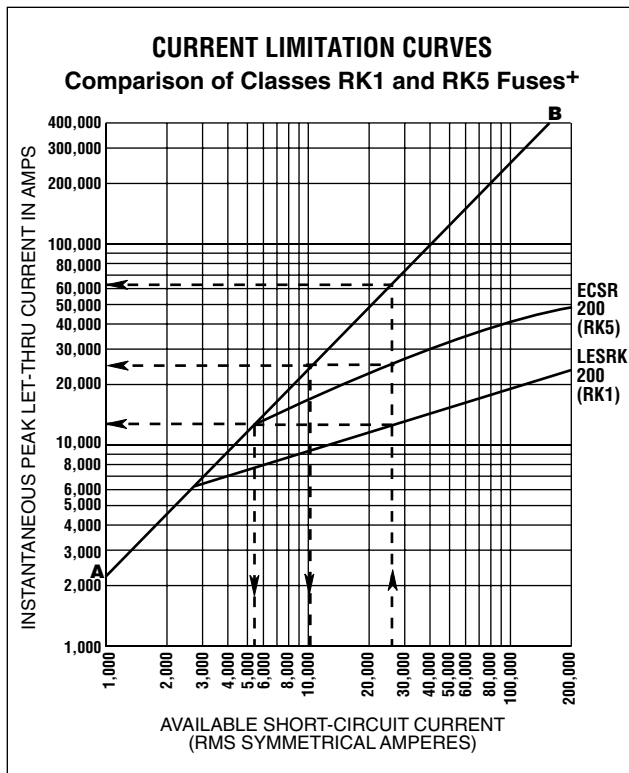

† Contact Edison Fusegear for latest data. Figure 17 shows an  $I_p$  value of 13,000 amperes for the LESRK 200 and a value 22,000 amperes for the ECSR 200. To compare with a non-limiting device, start at the 27,300 Irms current again and move vertically along the dashed line. Instead of stopping at the ECSR curve, continue vertically to the line A-B. At this intersection, move horizontally left to the vertical  $I_p$  scale to read about 65,000 peak amperes let-through for a 200 amp non-limiting overcurrent protection device. This indicates an  $I_p$  of about 500% more than a LESRK 200.

The time/current curve of the LESRK 200 fuse (Figure 18) indicates a time-delay of about 19 seconds to override the motor starting current of 960 amps (160 F.L.A. motor). This allows the motor to operate normally without unnecessary fuse oversizing that may reduce protection. The SCLR 200 fast-acting fuses would not allow the motor to start, for the fuse would open in approximately 1.1 seconds due to inrush current. This condition would require SCLR oversizing to about 400 amps to allow the motor to start. Such fuse oversizing not only reduces protection, but increases equipment size and cost.

The ECSR 200 has about the same time-delay as the LESRK 200

for fuse operating times of about 0.35 seconds and longer. The difference between the LESRK and ECSR curves for time less than 0.35 seconds is an indication of the greater current limitation for an LESRK fuse.

## Motor Overload (Running) Protection

Class R (RK) time-delay fuses (Both RK1 and RK5) are recognized by the N.E.C. for use as primary motor overload (running) protection. Refer to N.E.C. 430-36.

When EDISON LENRK/LESRK or ECNR/ECSR fuses are used for primary motor overload protection, it is recommended that the fuses be sized as closely as practical to the actual measured motor amperes for normal motor operation. Otherwise, fuse sizing for primary overload protection is acceptable by the N.E.C. when sized for not more than 125% of the motor nameplate F.L.A. for motors with a Service Factor not less than 1.15 or motors with a temperature rise not over 40 Degrees Celsius. For all other motors the fuses shall not be sized over 115%. This applies to typical motors in typical applications. Special motors or applications require additional analysis.

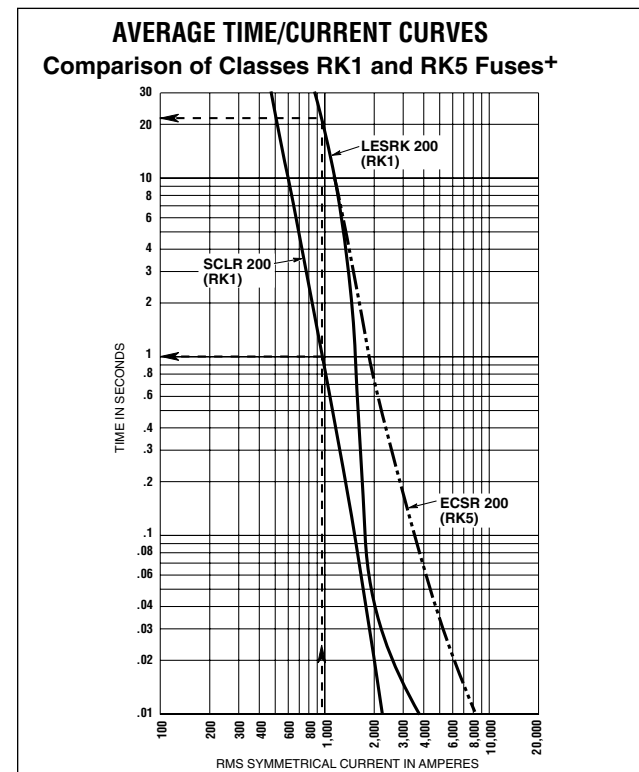

When motor controller thermal overload relays are used (Figure 18 Figure 19), time-delay fuses are recommended to be sized for “back-up” motor overload protection for the motor controller overload relays in the event that they fail to operate. Such fuse sizing will provide a reasonable degree of motor overload protection. It is desirable that the overload relays have an opportunity to open first—which is a function of relay/fuse time/current curves comparison or an estimate at 10-15% operating time differential.