

OMB-LOGBOOK-300

Stand-Alone, Intelligent PC-Based Data Acquisition System

\$3999
Basic Unit



The OMB-LOGBOOK-300, \$3699, data acquisition system with PC-Card memory and Remote Operation Terminal

- ✓ Operates Without a PC at the Test Site
- ✓ 16-Bit, 100-kHz Sampling
- ✓ Compact Yet Expandable Architecture Can Accommodate Over 400 Channels of Analog, Digital & Frequency I/O
- ✓ Stand-Alone Nonvolatile Storage of Over 250 Million Samples Via Removable PC-Card Memory
- ✓ Card Swapping and Uploading During Acquisition Allows Continuous Data Acquisition
- ✓ Optional Control Terminal Provides Channel Inspection and Acquisition Queries

- ✓ AC or DC Powerable
- ✓ Expansion Cards & Modules for High-Voltage/Current, Strain Gages, Thermocouples, Isolation, Relays, Accelerometers, Filtering & Simultaneous Sample & Hold
- ✓ Includes LogView Software for Easy Setup, Calibration, & More; No Programming Required
- ✓ Acquisition Configurations Can Be Transported to the OMB-LOGBOOK-300 Via PC-Card or via Serial or Parallel Port Connection
- ✓ Includes PostView for Post-Acquisition Data Viewing

The OMB-LOGBOOK-300 is a portable data acquisition system that can be used for remote, portable and unattended operation. It is also operational with a PC attached.

The OMB-LOGBOOK-300 combines on-board intelligence and a large capacity PC-Card removable memory with the industry's easiest and most powerful data logging software. Its 16-bit, 100-kHz A/D and triggering capabilities make it ideal for collecting high and low speed phenomena. A comprehensive array of signal conditioning expansion cards and modules are offered that allow the OMB-LOGBOOK-300 to take measurements from virtually any transducer, from thermocouples to accelerometers.

The OMB-LOGBOOK-300 data acquisition system includes LogView graphical display and acquisition software, which allows for fast setup and easy use, with no programming required. LogView software uses a spreadsheet metaphor rather than programming to configure the channels and the acquisition parameters.

Operating Modes

Once an acquisition configuration has been developed, it can be downloaded to a PC-Card for transport to a remote OMB-LOGBOOK-300, or it can be directly downloaded to an attached OMB-LOGBOOK-300 via the serial or parallel port.

The OMB-LOGBOOK-300 can be used in stand-alone mode where no PC is present, or it can be linked to a PC via a serial or parallel port for interactive data collection.

A PC running LogView can interact with an attached OMB-LOGBOOK-300 at any time, both during the setup and/or while the acquisition is taking place. To observe acquired data, channel values can be displayed in any or all of LogView's many real-time indicators.

Removable Nonvolatile Memory

The OMB-LOGBOOK-300 requires a standard Type I, Type II, or Type III solid-state or hard drive ATA PC-Card for use as its nonvolatile memory. The cards can transport acquisition configurations and collected data between the PC and the OMB-LOGBOOK-300. Using a 500-Mbyte PC-Card, for example, you can store up to 250 million samples equating to more than 40 minutes of recording time at the full 100-kHz acquisition rate.

The OMB-LOGBOOK-300 supports standard ATA memory PC-Cards, as well as other PC-Cards.

OMB-LOGBOOK-300 OPERATING MODES

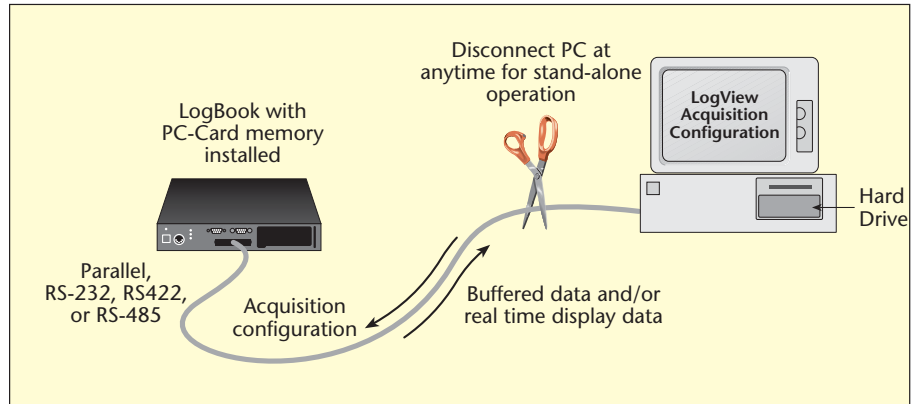

LogView can download acquisition configurations over any of its communication interfaces. Stored data and real-time readings can be uploaded in the same way.

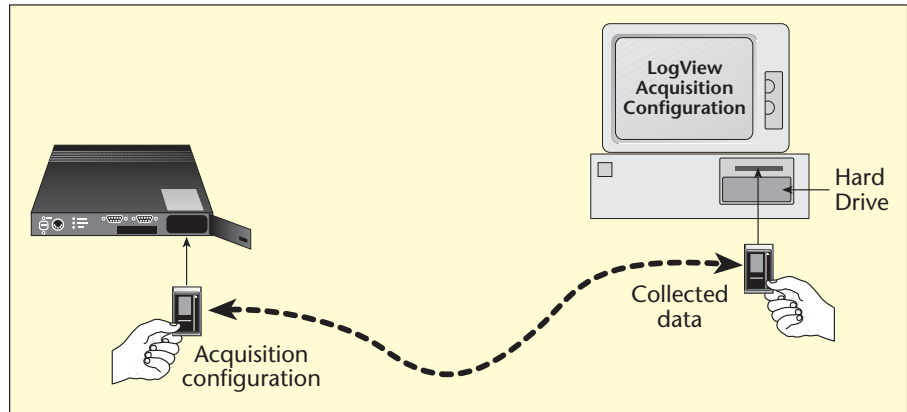

LogView downloads an acquisition configuration to a PC-Card in the PC's socket for transport to a remote OMB-LOGBOOK-300. Data is transported back to the PC via the PC-Card.



One PC-Card can be removed and another PC-Card inserted without causing a gap in the acquired data.

SOPHISTICATED TRIGGERING AND SAMPLING

Along with simple triggering and continuous data logging, the OMB-LOGBOOK-300 can be configured to intelligently collect only the data you want. For sophisticated triggering, a calculated channel can be specified as the trigger or the stop event. A calculated channel can describe virtually any combination of channel conditions. For example, you can develop a calculated channel called TRIG and specify it as the trigger channel. If the channel's equation is $TRIG = (Temp1 - Temp2) > 50.0$, the data collection process will be triggered when the difference between the two temperature channels is above 50.0 degrees.

The OMB-LOGBOOK-300 is capable of continuous, gapless data collection or for exception capturing using triggering.

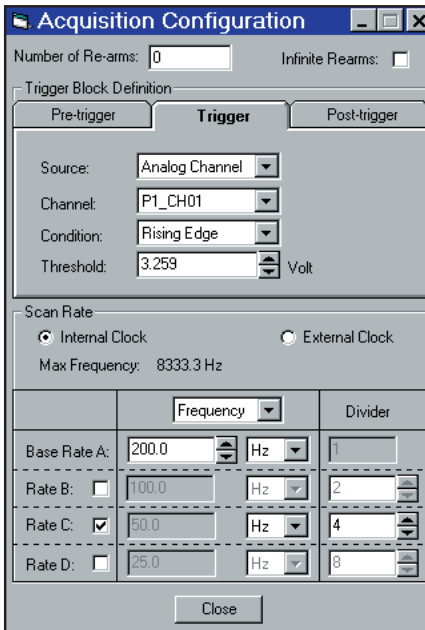
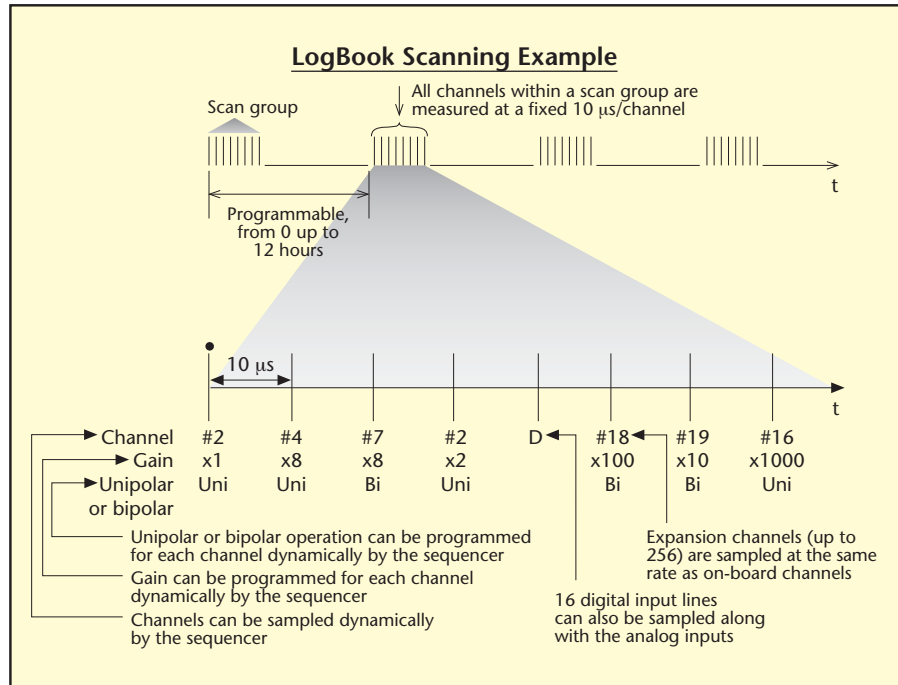

Acquisition configuration dialog box

CHANNEL-SCANNING FLEXIBILITY

The OMB-LOGBOOK-300 offers a scan sequencer that allows you to select each channel and associated input amplifier gain at random. The sequencer circuitry circumvents a major limitation encountered with many plug-in data acquisition boards—a drastic reduction in the scan rate for external expansion channels. All inputs, including analog, digital, counter, and calculated channels, are sampled at 100 KHz allowing time correlation of mixed signals. The OMB-LOGBOOK-300 permits each scan group to be repeated immediately or at programmable intervals for up to 10 hours. Within each scan group,

consecutive channels are measured at a fixed 10 μs/channel rate. If data collection is only desired under specific conditions, an appropriate trigger can be specified. When using a trigger to start the acquisition, a pre-trigger count can be supplied so that information just before the trigger can be collected and saved. The stop event definition specifies when the data collection activity should end. A wide variety of trigger sources and stop event choices provides a high degree of exception capture flexibility. For example, the OMB-LOGBOOK-300 can be configured to capture all data from all input channels for as long as the temperature difference between channels 1 & 2 is greater than 50 degrees.

For downloading acquisition configurations to a remote OMB-LOGBOOK-300 or uploading collected data to a PC, these cards can be inserted directly into your PC's standard PC-Card socket. No card reader or additional hardware is necessary to interact with the data.

For continuous data collection, PC-Cards can be swapped while the acquisition is taking place. As one card becomes nearly full, it can be removed and another card inserted without causing a gap in the acquired data.

During the card swapping process, acquired data is temporarily stored in the OMB-LogBook-300's internal 4 Mbyte RAM. If card swapping is required during a fast acquisition, a 16 Mbyte memory option is available. At 100 kHz sampling, the standard 4 Mbytes of RAM memory provides approximately 10 seconds to swap cards, while the 16 Mbyte option provides over 1 minute.

At slower acquisition speeds, there is even more time to swap cards. At 10 kHz, the standard 4M RAM memory provides approximately 1.5 minutes of swap time, while the 16M RAM upgrade provides more than 11 minutes of swap time.

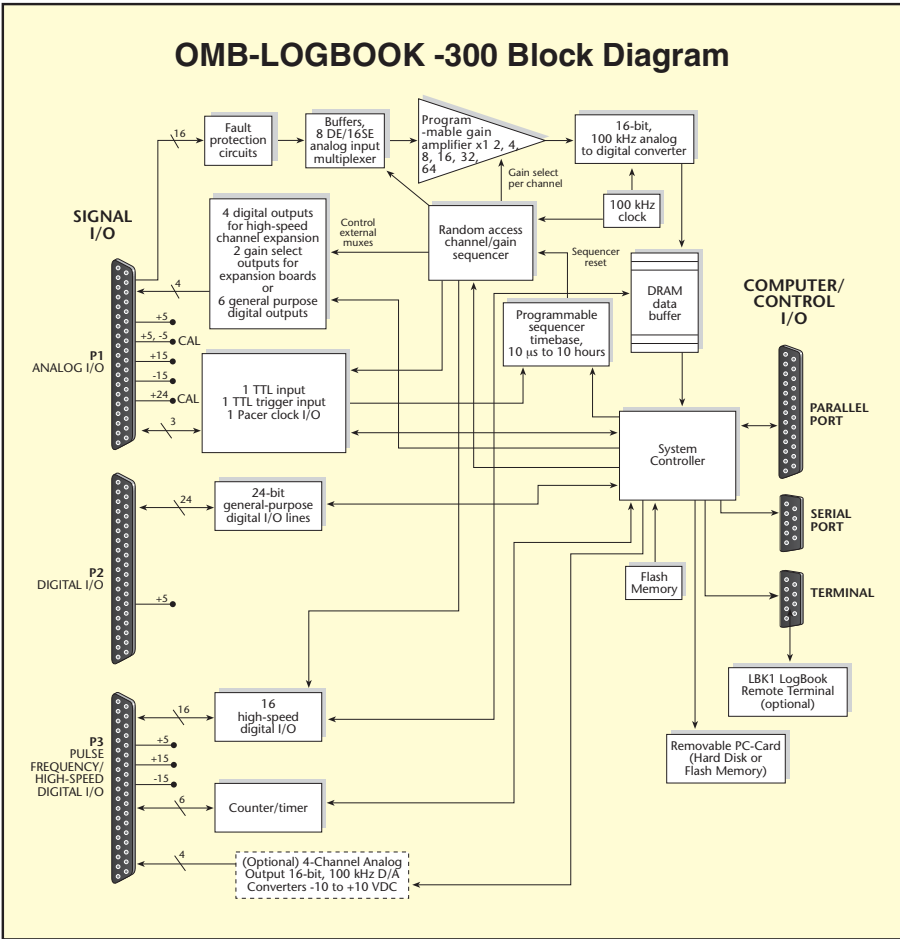

I/O, EXPANSION AND SIGNAL CONDITIONING

The OMB-LOGBOOK-300 data acquisition system is equipped with the following I/O:

- 16 single-ended or 8 differential analog inputs, with 6 programmable ranges:
Bipolar: 10 V, 5 V, 2.5 V, 1.25 V, 0.625 V, 0.3125 V, 0.15625 V
Unipolar: 20 V, 10 V, 5 V, 2.5 V, 1.25 V, 0.625 V, 0.3125 V
- 40 lines of general purpose digital I/O
- 4 pulse counting channels for totalizing and frequency measurement
- 2 pulse train outputs
- 4 optional 16-bit, 100 kHz analog outputs

The system can be expanded using a comprehensive line of signal conditioning and expansion options. The OMB-LOGBOOK-300 is expandable to up to 256 analog inputs and 208 digital I/O lines. Economical signal conditioning hardware includes thermocouple, RTD, high gain, high voltage, current, strain gage, accelerometer, frequency, filter, and simultaneous sample and hold.

All of the channels in an OMB-LOGBOOK-300 system, including the base I/O and expansion channels, are sampled synchronously, providing time correlation of all collected data. The OMB-LOGBOOK-300 provides both internal and external pacer clock control so that scans can be collected using the OMB-LOGBOOK-300's internal programmable oscillator or an externally supplied custom frequency clock.

Unlike many multiplexed input data loggers, the OMB-LOGBOOK-300's base analog input channels have a unique buffer-amplifier-per-channel design to eliminate noise and channel-to-channel crosstalk while maximizing accuracy - even with high-impedance transducers. For ease of use, all of the OMB-LOGBOOK-300's settings are software controlled, eliminating the need for switches and jumpers. Each channel is digitally calibrated, eliminating drift-prone potentiometers.

Unlike many plug-in board data acquisition systems, the OMB-LogBook-300's programmable channel/gain sequencer scans expansion channels at the same rate as its on-board channels. For this reason, the OMB-LOGBOOK-300 is well suited for test applications that require both high channel-count and high speed.

LOGVIEW SOFTWARE SIMPLIFIES SETUP

LogView uses a series of spreadsheets to allow simple setup and display of all channel parameters. No auxiliary dialog boxes, configurable block diagrams, or programming methodologies are employed. Simply select the appropriate cell, choose the desired setting from the dropdown list, and the parameter is set. To apply the same setting to multiple channels, select a block of cells within a column and use the spreadsheet's fill-down feature.

After the channels and the acquisition parameters have been configured, download the configuration to a PC-Card in one of your PC's sockets, or send the configuration directly to the OMB-LOGBOOK-300 via the serial or parallel port. When a PC-Card is used to transport the acquisition configuration to a remote OMB-LOGBOOK-300, inserting the card into one of its sockets signals the OMB-LOGBOOK-300 to read and execute the new acquisition configuration.

Once the channel configuration parameters have been downloaded to the OMB-LOGBOOK-300, LogView can display the channel values of a connected OMB-LOGBOOK-300 in real time, both before and during an acquisition. LogView conveniently displays channel values in the channel configuration spreadsheet or in real-time bargraphs, analog meters, and digital indicators.

SPREADSHEETS MAKE IT SIMPLE

All of the parameters for the analog I/O, digital I/O, frequency and calculated channels can be viewed and adjusted through LogView's unique spreadsheet interface.

The spreadsheets make it possible to see and adjust the parameters of many channels concurrently, unlike typical data parameters of many channels concurrently, unlike typical data

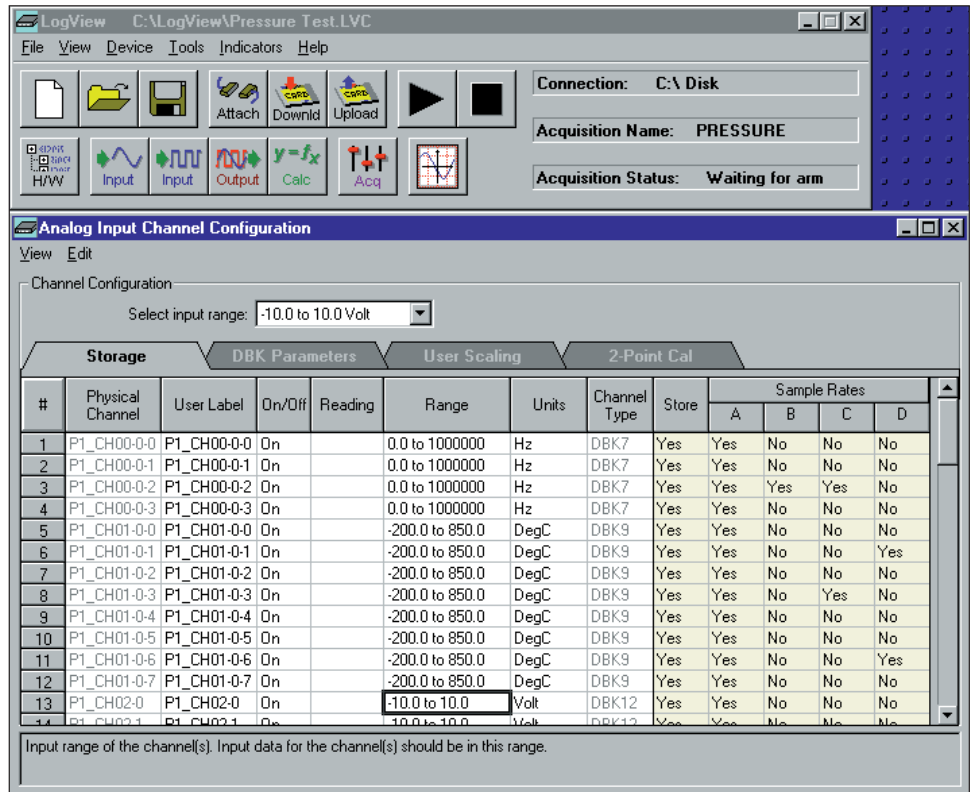

LogView's analog input spreadsheet makes viewing and adjusting many channels easy

logging software that requires channels to be set up one at a time through auxiliary dialog boxes.

Channel parameters are independent of one another.

Channel parameters include:

- Turning the channel on or off
- Programmable input range for analog input channels
- Scaling and offset for engineering units conversion
- Any or all of 4 timebases to log the channel
- The equation that defines the calculated channel

- The physical output channel to direct a calculated or input channel

- Special parameters specific to certain signal conditioning modules

All inputs including analog, digital, frequency and calculated channels are collected synchronously so that data from widely dissimilar inputs can be correlated in time.

Within the analog spreadsheet, an offset adjustment or 2-point calibration can be performed for each channel. This function compensates for inaccuracies in signal conditioning circuitry and sensors.

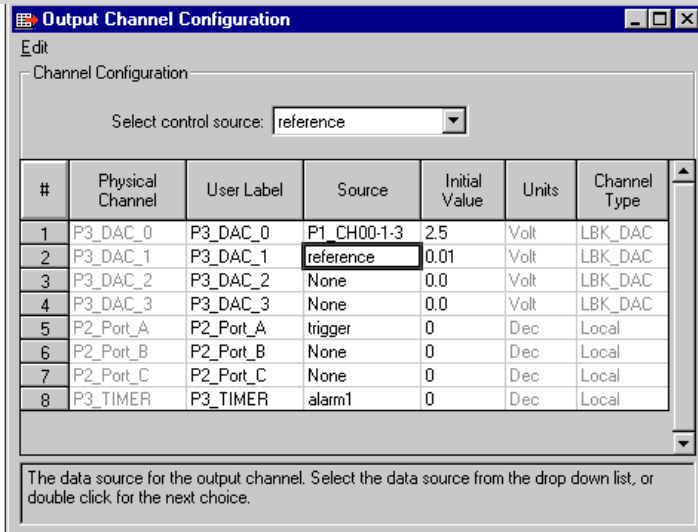

Output functions are easily controlled using calculated channels

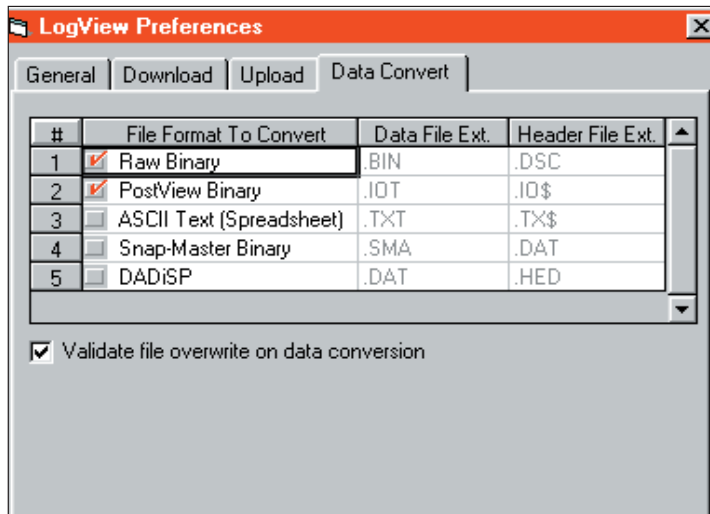

LogView can convert collected data to several file formats

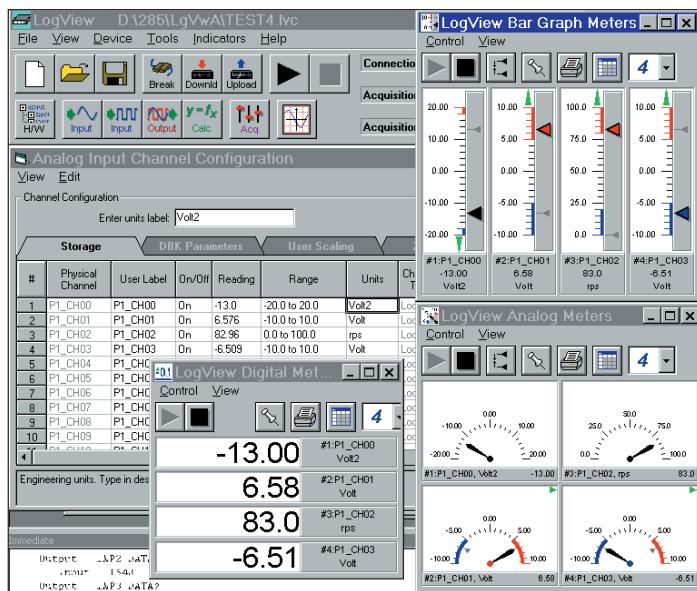

Real-time indicators provide channel feedback from an attached OMB-LOGBOOK-300

ANALOG AND DIGITAL OUTPUTS

The OMB-LOGBOOK-300's analog and digital outputs allow it to control external devices and/or stimulate the unit-under-test. Using LogView's calculated channels, equations can be derived that can be used to stimulate digital outputs for use as alarms or for on/off control. For example, the equation $DIG1 = (CH1 - CH2) < 20$ turns on digital output 1 if the difference between channels 1 and 2 is less than 20.

The system's four 16-bit analog outputs can also be used for controlling or stimulating external devices. Using channel data derived from input channels and equations, the analog output channels can be used for soft control.

DATA FORMATS AND DATA FILES

Data collected with the OMB-LOGBOOK-300 can be uploaded to your PC's hard disk in any or all of several data formats for post-acquisition analysis. Some of the available file formats include Excel, Snap-Master, MATLAB, DASyLab, Lotus, Quattro, and ASCII, which are compatible with virtually all post-acquisition analysis software. LogView creates the necessary headers for each data format so that the post-acquisition analysis software can use the channel labels, the acquisition timebase information, and other necessary parameters.

AUXILIARY REAL-TIME INDICATORS

Along with displaying channel data from an attached OMB-LOGBOOK-300 in real time in the setup spreadsheets, LogView also provides real-time indicators. These indicators provide a means of monitoring the real-time channel values so that signals can be verified. Each indicator provides a high degree of setup flexibility to customize your display.

POSTVIEW

Included with LogView, PostView post-acquisition waveform display software provides graphical displays, which are similar to those provided by stripchart recorders, for viewing up to 16 channels of previously acquired data at one time. Using the program's intuitive on-screen controls, you can expand, contract, and auto-scale waveforms as well as manually scroll in either direction. PostView is the perfect tool for browsing through data collected to disk.

REMOTE OPERATION TERMINAL

The optional OMB-LBK1 Remote Operation Terminal connects directly to the OMB-LOGBOOK-300, providing control of the OMB-LOGBOOK-300 without a computer. Without the terminal, the OMB-LOGBOOK-300 is immediately armed once power is applied and a programmed PC-Card is present. With the terminal connected, operation can be started and stopped with a push of a button. The terminal requires no external power connection.

- The terminal connects to the OMB-LOGBOOK-300 via a standard 6-pin RJ11 to RJ11 modular telephone cable up to 100 feet long.
- The rugged terminal provides many useful functions including:
- Inspect Channel Values
- Query Channel Values
- Query acquisition status
- Check disk status
- Manually mark events using the keyboard, tagging a location in the file

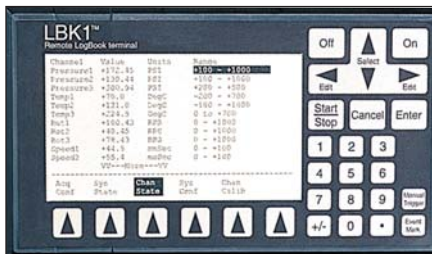

The optional OMB-LBK1 Remote Operation Terminal provides control of the OMB-LOGBOOK-300 system in the field when no PC is present

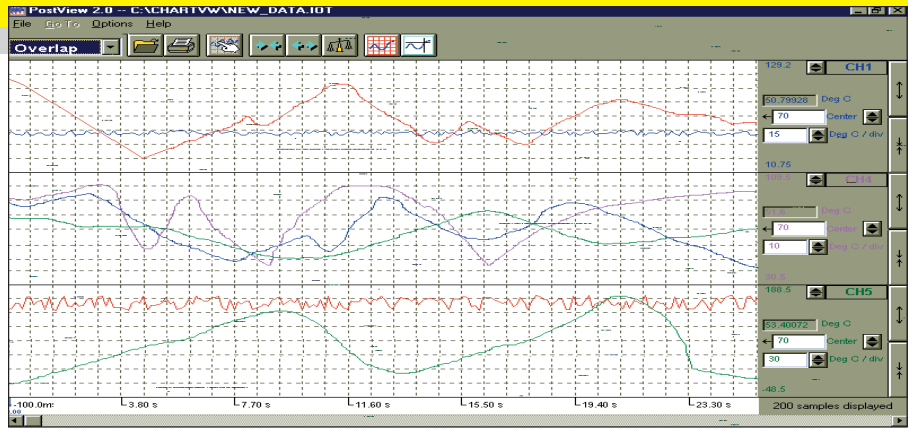

PostView for post-acquisition viewing

SPECIFICATIONS

GENERAL

Power Consumption:

0.9 A @ 15 V

Operating Temperature:

-15 to 50°C

Storage Temperature: 0 to 80°C

Humidity: 0 to 95%

RH non-condensing

Dimensions: 220 x 279 x 44 mm
(8.5 x 11 x 1.75")

Weight: 1.5 kg (3.3 lbs)

PC-Card Memory:

Standard ATA Type

A/D Specifications

Type: Successive approximation

Resolution: 16 bit

Conversion Time: 10 µs

Monotonicity: No missing codes

Linearity: ±1 bit

ANALOG INPUTS

Channels: 16 single-ended, 8 differential, expandable to 256 differential; single-ended or differential operation is software programmable

Connector: DB37 male, P1

Resolution: 16 bits

Accuracy: ±0.01% FS

Ranges:

Unipolar/bipolar operation is switch selectable

Unipolar:

0 to +20 V, 0 to +10 V,

0 to +5 V, 0 to +2.5 V, 0 to +1.25 V,

0 to +0.625 V, 0 to +0.3125 V

Bipolar:

±10 V, ±5 V, ±2.5 V, ±1.25 V,

±0.625 V, ±0.3125 V, ±0.15625 V

Maximum Overvoltage:

-35 V to +45 V

Input Current

Differential: 0.4 µA typ/0.7 µA max

Single-ended:

0.2 µA typ/0.35 µA max

Input Impedance

Single-Ended:

5M Ohm in parallel with 30 pF

Differential:

10M Ohm in parallel with 20 pF

TRIGGERING

Analog Trigger

Programmable Level Range:

Full range of specified channels

Digital Trigger

Logic Level Range:

0.8 V low/2.2 V high

Trigger to A/D Latency: 10 µs max

Software Trigger

Trigger to A/D Latency:

Dependent on PC

Pre-Trigger: Up to 4 gig scans,

depending on size of PC-Card memory

SEQUENCER

Randomly programmable for channel & gain

Depth: 512 location

Channel-to-Channel Rate:

10 µs/channel, fixed

Maximum Repeat Rate: 100 kHz

Minimum Repeat Rate: 10 hours

Expansion Channel Sample Rate:

Same as on-board channels,

10 µs/channel

ANALOG OUTPUT OPTION (INTERNAL)

Channels: 4

Connector: DB37 male, P3

Resolution: 16 bit

Voltage Range: ±10 V

Maximum Output Current: 10 mA

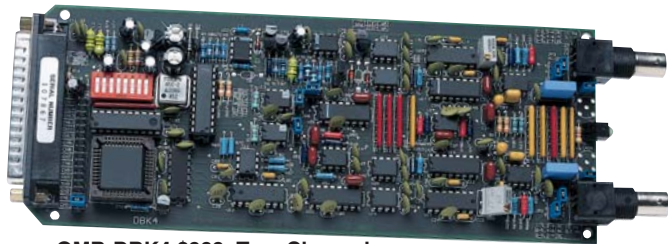

OMB-DBK4 \$999, Two-Channel Dynamic Signal-Input Card, shown smaller than actual size

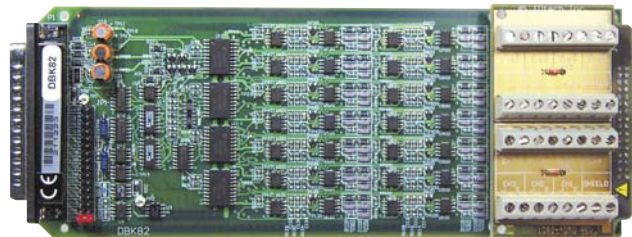

OMB-DBK82, \$849, High-Accuracy Thermocouple Card, shown smaller than actual size



OMB-DBK7, \$749, Four-Channel Frequency-Input Card, shown smaller than actual size

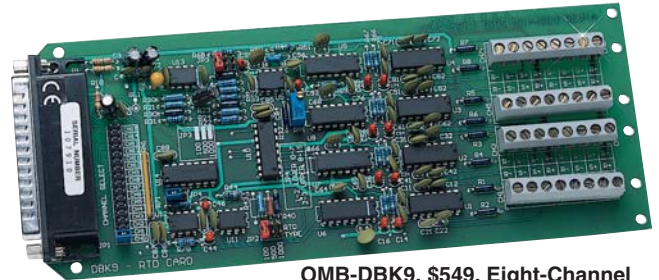

OMB-DBK9, \$549, Eight-Channel RTD Measurement Card, shown smaller than actual size

The OMB-LOGBOOK-300 is compatible with a comprehensive line of signal conditioning expansion cards. See the H section of the handbook for details.

GENERAL PURPOSE DIGITAL I/O

Channels: 40 I/O channels, expandable up to 208
 Connector: DB37 male, P2
Output Voltage Levels
 Minimum "1" Voltage: 3.0 @ 2.5 mA sourcing
 Maximum "0" Voltage: 0.4 @ 2.5 mA sinking
Output Current
Maximum Source Current: 2.5 mA
Maximum Sink Current: -2.5 mA
Input Voltage Levels
 Minimum Required "1" Voltage Level: 2V
 Maximum Allowed "0" Voltage Level: 0.8V
 Output Float Leakage Current: 10 µA

FREQUENCY/PULSE COUNTERS

Channels: 4
 16-bits per channel, cascadable
Connector: DB37 male, P3
Maximum Pulse Count: 32-bit binary (2 channels cascaded)
Maximum Input Rate: 1 MHz
Input Voltage: -15V to +15V
Threshold Voltage
Low: 0.8V typ, 0.5V min
High: 1.6V typ, 2.1V max
Hysteresis: 400 mV min
Pulse Width Low or High: 520 ns min
Input Impedance: 27K Ohm pull-up to +5V in parallel with 50 pF

FREQUENCY/PULSE GENERATOR

Channels: 2, 16-bits
Connector: DB37 male, P3
Frequency/Pulse Generating Mode: Input frequency divided by 1 to 65,535
Input Low Voltage: 0.8V max
Input High Voltage: 2V min
Input Low Current: -10 µA max
Input High Current: 10 µA max
Output High Voltage: 2.4V min @ -8 mA
Output Low Voltage: 0.5V max @ 8 mA

ALL MODELS AVAILABLE FOR FAST DELIVERY!

To Order (Specify Model Number)

Model Number	Price	Description
OMB-LOGBOOK-300	\$3999	PC-based data acquisition system, requires 1GB rotating hard drive memory (OMB-MEMCARD-10)
OMB-MEMCARD-10	495	1GB rotating hard drive memory
OMB-LBK-1	799	Hand-held terminal with 0.6 m (2') cable
OMB-LBK-COMM-422-485	209	RS-422 and RS-485 interfaces added to existing RS-232 and parallel port

The OMB-LOGBOOK-300 includes LogView software, parallel port cable and a complete user's manual.
Ordering Example: OMB-LOGBOOK-300 Data Acquisition System, OMEGACARESM 1 year extended warranty for the OMB-LOGBOOK-300 (adds 1 year to standard 1 year warranty) and OMB-MEMCARD-10 1 GB rotating hard drive memory, \$3999 + 495 + 150 = \$4644.



UNITED STATES

www.omega.com
1-800-TC-OMEGA
Stamford, CT.

CANADA

www.omega.ca
Laval(Quebec)
1-800-TC-OMEGA

GERMANY

www.omega.de
Deckenpfronn, Germany
0800-8266342

UNITED KINGDOM

www.omega.co.uk
Manchester, England
0800-488-488

FRANCE

www.omega.fr
Guyancourt, France
088-466-342

CZECH REPUBLIC

www.omegaeng.cz
Karviná, Czech Republic
596-311-899

BENELUX

www.omega.nl
Amstelveen, NL
0800-099-33-44



More than 100,000 Products Available!

• Temperature

Calibrators, Connectors, General Test and Measurement Instruments, Glass Bulb Thermometers, Handheld Instruments for Temperature Measurement, Ice Point References, Indicating Labels, Crayons, Cements and Lacquers, Infrared Temperature Measurement Instruments, Recorders Relative Humidity Measurement Instruments, RTD Probes, Elements and Assemblies, Temperature & Process Meters, Timers and Counters, Temperature and Process Controllers and Power Switching Devices, Thermistor Elements, Probes and Assemblies, Thermocouples Thermowells and Head and Well Assemblies, Transmitters, Wire

• Flow and Level

Air Velocity Indicators, Doppler Flowmeters, Level Measurement, Magnetic Flowmeters, Mass Flowmeters, Pitot Tubes, Pumps, Rotameters, Turbine and Paddle Wheel Flowmeters, Ultrasonic Flowmeters, Valves, Variable Area Flowmeters, Vortex Shedding Flowmeters

• pH and Conductivity

Conductivity Instrumentation, Dissolved Oxygen Instrumentation, Environmental Instrumentation, pH Electrodes and Instruments, Water and Soil Analysis Instrumentation

• Data Acquisition

Auto-Dialers and Alarm Monitoring Systems, Communication Products and Converters, Data Acquisition and Analysis Software, Data Loggers Plug-in Cards, Signal Conditioners, USB, RS232, RS485 and Parallel Port Data Acquisition Systems, Wireless Transmitters and Receivers

• Pressure, Strain and Force

Displacement Transducers, Dynamic Measurement Force Sensors, Instrumentation for Pressure and Strain Measurements, Load Cells, Pressure Gauges, Pressure Reference Section, Pressure Switches, Pressure Transducers, Proximity Transducers, Regulators, Strain Gages, Torque Transducers, Valves

• Heaters

Band Heaters, Cartridge Heaters, Circulation Heaters, Comfort Heaters, Controllers, Meters and Switching Devices, Flexible Heaters, General Test and Measurement Instruments, Heater Hook-up Wire, Heating Cable Systems, Immersion Heaters, Process Air and Duct, Heaters, Radiant Heaters, Strip Heaters, Tubular Heaters