

MULTI-PARAMETER INPUT TRANSMITTER For Flow



DPU91-FLOW Series



- ✓ Large Auto-Sensing Backlit Display
- ✓ “Dial-Style” Digital Bar Graph
- ✓ Intuitive and “User-Friendly” Interface
- ✓ Optional Field Upgradable Relays
- ✓ Warning LED Indicator
- ✓ Custom 13-Character Label Capabilities
- ✓ Factory Reset Capability

The DPU91 transmitter provides a single channel interface for many different parameters including flow, pH/ORP, conductivity/resistivity, salinity and temperature. The DPU91-BC transmitter has the added capability of supporting the batch module for batching control. The extra-large (3.90 x 3.90") autosensing backlit display can be viewed at 4 to 5 times the distance over traditional transmitters. The highly illuminated display and large characters reduce the risk of misreading or misinterpreting the displayed values. The display shows separate lines for units, main and secondary measurements as well as a “dial-style” digital bar graph.

The DPU91 is offered in both panel or field-mount versions. Both configurations can run on 12 to 32 Vdc power (24 Vdc nominal). Designed for complete flexibility, plug-in modules allow the unit to easily adapt to meet changing customer needs. Optional modules include relay, direct conductivity/resistivity, batch and a PC communications configuration tool. The unit can be used with default values for quick and easy programming or can be customized with labeling, adjustable minimum and maximum dial settings, and unit and decimal measurement choices.



DPU91 shown smaller than actual size.

SPECIFICATIONS

General

Input Channels: 1

Input Types: Digital serial ASCII, TTL level, 9600 bps

Frequency Range: 0.5 to 1500 Hz

Accuracy: 0.5% of reading (display)

Measurement Types: Flow, pH/ORP, conductivity/resistivity, salinity, pressure, temperature or batch

Enclosure and Display

Case Material: PBT

Window: Shatter-resistant glass

Keypad: 4 buttons, injection-molded silicone rubber seal

Display: Backlit, 7 and 14-segment

Update Rate: 1 second

LCD Contrast: 5 settings

Indicators: “Dial-style” digital bar graph, LEDs for open collector, relays and warning indicator

Enclosure: ¼ DIN, NEMA 4X/IP65

Mounting Panel: ¼ DIN, ribbed on four sides for panel mounting clip inside panel, silicon gasket (included)

Field Mounts: Specified to Omega field mount junction boxes

Weight: 0.63 kg (1.63 lb)

Display Ranges

For conductivity/resistivity version visit omega.com/dpu91_conductivity

For pH/ORP version visit omega.com/dpu91_ph

Flow Rate: -9999 to 99999 units per second, minute, hour or day

Totalizer: 0.00 to 99999999 units (program lockout or resettable)

Temperature: -99 to 350°C (-146 to 662°F)

Volume: 0 to 99999 cm³, m³, in³, ft³, gal, L, lb, kg, %

Environmental

Ambient Operating Temperature:

Backlit LCD: -10 to 70°C (14 to 158°F)

Storage Temperature: -15 to 70°C (5 to 158°F)

Relative Humidity: 0 to 100% condensing for field mount; 0 to 95% non-condensing for panel mount

Maximum Altitude: 4000 m (13,123')

Electrical Requirements

Power to Sensors:

Voltage: 4.9 to 5.5 Vdc @ 25°C, regulated short circuit protected

Terminal Blocks: Pluggable screw type 14 AWG maximum wire gauge

Input Power

DC: 10.8 to 35.2 Vdc, regulated

DPU91 without Relay Module:

200 mA @ 10.8 to 35.2 Vdc

DPU91 with Relay Module: 300 mA @

10.8 to 35.2 Vdc

Overvoltage Protection: 48 V

transient protection device current limiting for circuit protection and reverse-voltage protection

Current Output: 4 to 20 mA

(10.8 to 35.2 Vdc, 30 mA maximum)

Relay Specifications**Dry-Contact Relays:** 2**Open Collector:** 1**Type:** SPDT N/A**Form C:** N/A**Maximum Current Rating:** 5 A resistive
50 mA DC**Maximum Voltage Rating:** 30 Vdc or
250 Vac**Hysteresis Adjustable:** Absolute in
engineering units (EUs)**Latch Reset:** In test screen only**Delay:** 9999.9 seconds (maximum)**Test Mode:** Set on/off**Cycle Time:** 99999 seconds (maximum)**Maximum Pulse Rate:**

400 pulses/minute

Proportional Pulse: 400 pulses/minute**Volumetric Pulse Width:** 0.1 to 3200 s**Pulse Width Modulation:** 0.1 to 320 s**Input Types****Digital or AC Frequency:** pH/ORP
input via the digital output from the
PHTX-2750 pH/ORP sensor electronics
(For pH models see [omega.com/
dpu91_ph](http://omega.com/dpu91_ph))**Conductivity/Resistivity:** Input
directly from OMEGA conductivity/
resistivity electrodes via direct
conductivity/resistivity module or via
CDTX-2850 (For conductivity/resistivity
models see [omega.com/
dpu91_conductivity](http://omega.com/dpu91_conductivity))**Input Specifications****Digital Serial:** ACSII, TTL level,
9600 bps**Frequency Input:****Sensitivity:** 80 mV @ 5 Hz, gradually
increasing with frequency**Span:** 0.5 Hz to 1500 Hz @ TTL
level input**Accuracy:** ± 0.5% or reading maximum
error @ 25°C (77°F)**Repeatability:** ±0.2% of reading

DPU91 Series with Mating Flow Sensors		
	DPU91 or DPU91-BC	DPU91P or DPU91P-BC
FP-5100, FP-5200, FP-5300, FPB100, FMG3000	FP90UM and *sensor installation fitting, DPU90-AK (optional)	*Sensor installation fitting
Integral Mount FP-5600, FP-8500, FP-8500A	FP90IM and *sensor installation fitting, DPU90-AK (optional)	Panel mount displays cannot be mounted integrally to the sensor
FP-5061, FP-5070, FP-2540, FMG-550	FP90UM, DPU90-AK (optional)	

* Sensor installation fitting information can be found at omega.com/fp_fittings.

FMG3002



FP-5300



FMG-553

FP-2541



FP-5200

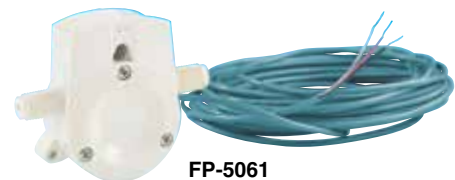

FP-8500

All model shown
smaller than actual size.

FP-5061

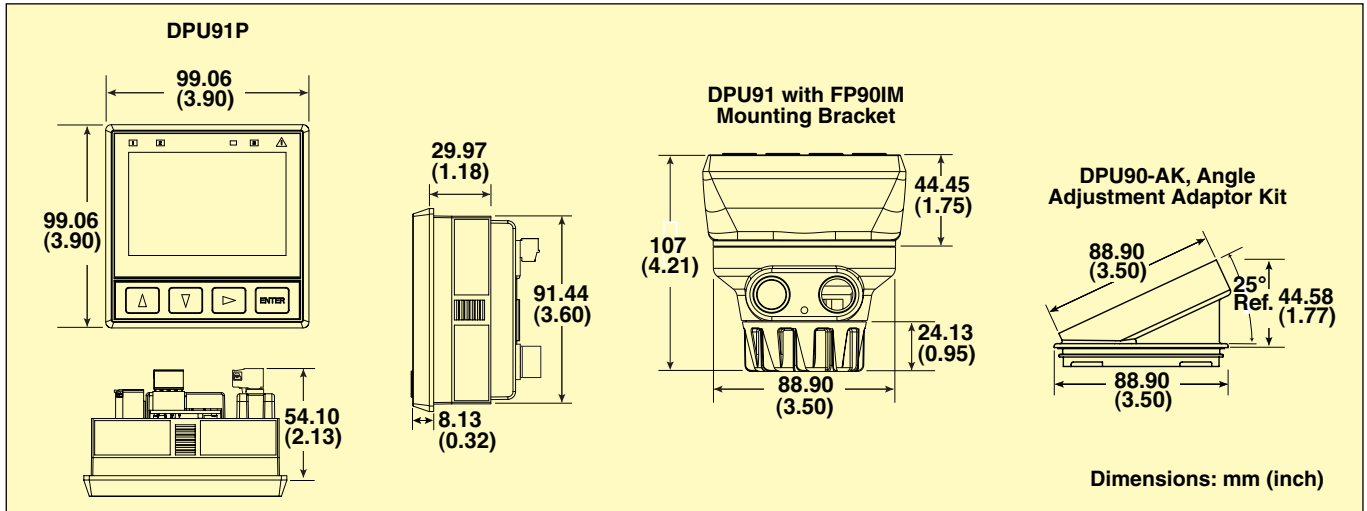

To Order	
Model No.	Description
DPU91	DC powered field mount multi-parameter display and transmitter
DPU91P	DC powered panel mount multi-parameter display and transmitter
DPU91-BC	DC powered field mount flow display and transmitter with batch control



Accessories

Model No.	Description
DPU90-R	Programmable dual relay output module, SPDT form C, 5 A resistive load
DPU90-COMM	Communications module, HART® protocol super imposes digital signal onto of 4 to 20 mA
DPU90-AK	Angle adjustment kit for field mount and conductivity/resistivity/salinity input units
DPU90-CT	PC configuration tool, includes software
FP90UM	Universal mounting bracket for field mounted units
FP90IM	Integral mounting bracket for use with field mount displays and integral sensors
FPM-5000-LTCK	Liquid tight connector kit for liquid tight wiring feed-thru

Comes complete with operator's manual (sensors, modules, and mounting kits sold separately).

Ordering Examples: DPU91, display/transmitter FP90UM universal mounting kit and FP-5061, low flow turbine. DPU91P, panel mount display, FP-5300 paddlewheel, and FP-5310 PVC tee fitting 1".