

## Flanged Immersion Heaters with Custom Size and Shape Flanges

### TPN7 Series

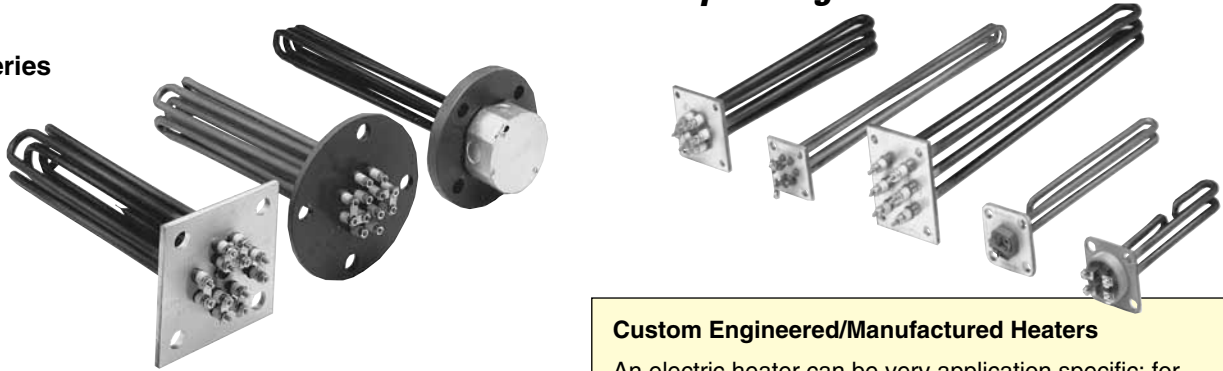

#### Typical Applications

- Hot Air Dryers
- Dehumidifying Dryers
- Heat Exchange Systems
- Water and Water Solutions
- Steam Tables
- Air Heating

#### Custom Immersion Heaters

This design consists of tubular heating elements silver brazed or TIG welded to a flange cut from steel or stainless steel plate. Flange plate size, thickness and shape are determined by the application. A fiber gasket is supplied with each heater. This type construction also lends itself to be easily and economically engineered into new equipment.

#### Custom Engineered/Manufactured Heaters

An electric heater can be very application specific; for sizes and ratings not listed, OMEGA will design and manufacture a flanged immersion heater to meet your requirements.

#### Please Specify the Following:

- ✓ Wattage, Voltage and Phase
- ✓ Element Immersion Length
- ✓ Flange Size and Material
- ✓ Electrical Enclosure, if required
- ✓ Element Sheath Material
- ✓ Optional Features
- ✓ Element Watt Density

### 6 1/2" Diameter Steel Flange, 6 Incoloy® 800 Elements, 1 Circuit

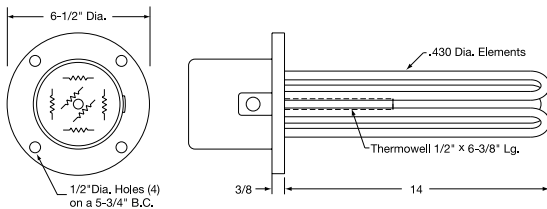

Supplied with gasket (GSK-102-103)

### To Order Visit [omega.com/tpn7](http://omega.com/tpn7) for Pricing and Details

Model No.	Approx Weight		Element Sheath Material	KW	Watt Density	
	kg	lb			Watt/cm <sup>2</sup>	Watt/in <sup>2</sup>
460V-3Ph			Incoloy® 800	9	7.1	46
TPN01706	4.5	10				
TPN01707	4.5	10				

Heaters can be factory rewired for 230V-3PH.

Ordering Example: TPN01706, 9 KW flanged immersion heater.

### 6 1/2" Diameter Steel Flange, 6 Elements, 2 Circuits

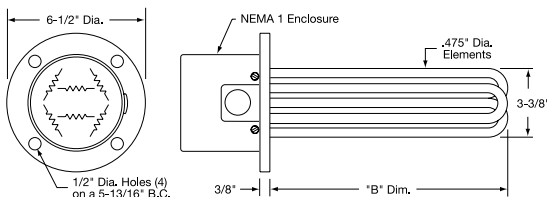

Supplied with gasket (GSK-102-103)

Model No.				Approx Weight		Element Sheath Material	KW	Watt Density		B	
208V-3Ph	230V-3Ph	460V-3Ph	575V-3Ph	kg	lb			Watt/cm <sup>2</sup>	Watt/in <sup>2</sup>	mm	inch
TPN01448	TPN01177	TPN01178	TPN01449	4.5	10	Incoloy® 800	9	7.8	50	432	17
TPN01450	TPN01451	TPN01452	TPN01453	4.5	10		10.5	8.1	42	432	17
TPN01454	TPN01204	TPN01179	TPN01455	4.5	10		12	7.8	50	432	17
TPN01319	TPN01456	TPN01321	—	4.5	10	Copper	12	7.4	48	432	17
TPN01457	TPN01458	TPN01459	—	5.4	12		15	10.9	70	711	28

Ordering Example: TPN01448, 9 KW, 208V, 3 phase flanged immersion heater.