

# FLANGED IMMERSION HEATERS FOR BOILERS AND WATER HEATERS



TTSF Series



- ✓ 2½" (6 cm) Square Steel Flange
- ✓ Premium Quality
- ✓ Rugged Construction
- ✓ UL Component Recognized

Type TTSF heaters are used in industrial water boilers and storage tanks. They feature high watt density for rapid heat transfer. The steam boiler heaters feature the highest quality, high nickel Incoloy® sheath that provides the highest practical protection available against hard water containing minerals, scale and salts while resisting stress, corrosion, cracking, and sulphur attack. The water heater has a copper sheath and copper face plate. These heaters are not supplied with enclosures since they are normally mounted in boilers or tanks which have a surrounding enclosure for terminal protection.

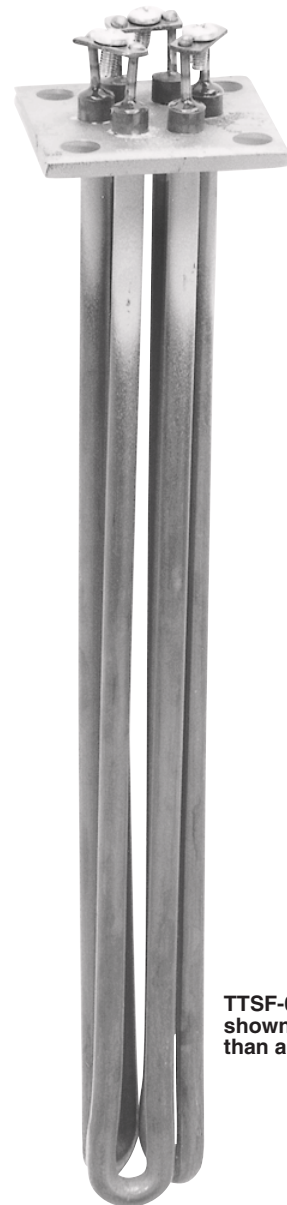

TTSF-009 shown smaller than actual size.

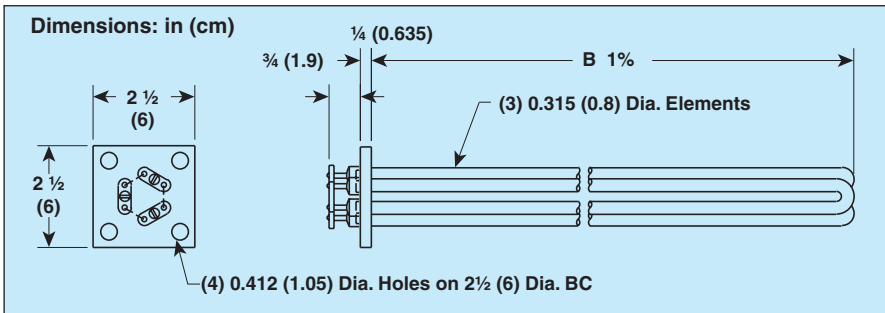

To Order							
kW	Volts	Circ.	Phase	W/in <sup>2</sup>	Dim. B in (cm)	Model No.	Wt. lb (kg)
<b>Steam Boiler Heater Specifications—Incoloy Sheath</b>							
5	208	1	3	94	12 (30)	TTSF-009	2 (0.9)
5	240	1	3	94	12 (30)	TTSF-010	2 (0.9)
10	208	1	3	79	24 <sup>7</sup> / <sub>16</sub> (61)	TTSF-005	3 (1)
10	240	1	3	79	24 <sup>7</sup> / <sub>16</sub> (61)	TTSF-006	3 (1)
10	480	1	3	79	24 <sup>7</sup> / <sub>16</sub> (61)	TTSF-007	3 (1)
15	208	1	3	82	34 (84)	TTSF-002	4 (2)
15	240	1	3	82	34 (84)	TTSF-003	4 (2)
15	480	1	3	82	34 (84)	TTSF-001	4 (2)
<b>Water Heater Specifications—Copper Sheath/Copper Face Plate</b>							
13.5	208	1	3	184	13 <sup>7</sup> / <sub>16</sub> (34)	TTSF-3135	2 (0.9)
13.5	480	1	3	184	13 <sup>7</sup> / <sub>16</sub> (34)	TTSF-3135	2 (0.9)
15	480	1	3	153	17 <sup>7</sup> / <sub>16</sub> (44)	TTSF-3150	3 (1)
18	480	1	3	153	21 <sup>1</sup> / <sub>16</sub> (53)	TTSF-3180	4 (2)

Ordering Examples: TTSF-009, 5 kW, 208V, flanged immersion heater Incoloy sheath. TTSF-3135, 13.5 kW 480V, immersion heater, copper sheath/copper face plate.

## SPECIFICATIONS

**Wattage:** 5 to 18 kW  
**Power:** 208 and 240 or 480 Vac, 3 Phase  
**Watt Density:** 79 to 184 W/in<sup>2</sup>  
**Sheath:** 0.315" (0.8 cm) dia. Incoloy (steam boiler heater) or copper (water heater)

## CAUTION AND WARNING!

Fire and electrical shock may result if products are used improperly or installed or used by non-qualified personnel. See inside back cover for additional warning.