

MANUAL TEST STAND FOR DFG80 SERIES FORCE GAGES

DISCONTINUED

DFG-TS Series

Reliable inspection is essential to successful quality control. OMEGA's DFG-TS manual test stand ensures consistent, identical measuring conditions by eliminating human error. In addition, the stand shortens inspection time, thereby greatly increasing work efficiency. DFG80 force gages are easily mounted to the test stand. The combination of OMEGA force gages and test stand creates a high-precision, compact load tester for a wide range of applications.

SPECIFICATIONS

Maximum Load: 99.8 kg (220 lb)

Stroke: 102 mm (4") maximum

Maximum Clearance: 127 mm (5")

Function:

DFG-TS-C: Push

DFG-TS-T: Pull

DFG81-100 force gage, sold separately.

DFG-TS-T shown smaller than actual size.

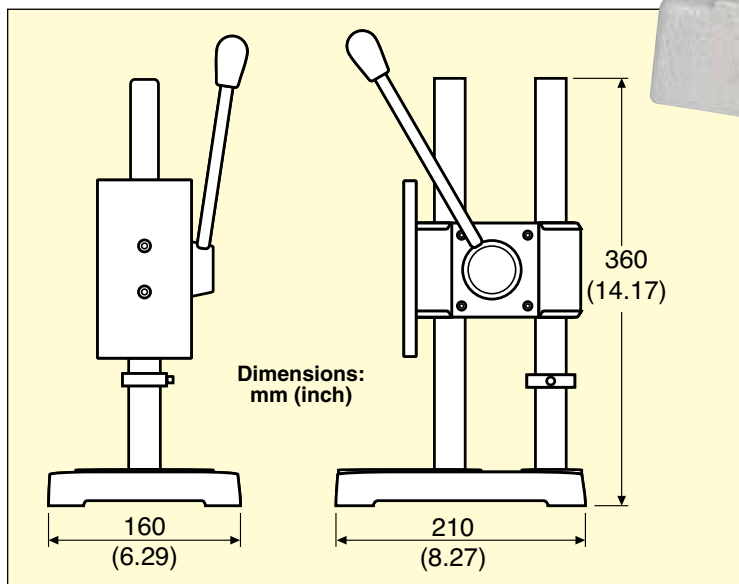

To Order

MODEL NO.	FUNCTION
DFG-TS-C	Push: Compression test stand
DFG-TS-T	Pull: Tension test stand

Comes complete with operator's manual.

Ordering Example: DFG-TS-T, tension test stand with pull function.

DISCONTINUED