

GENERAL PURPOSE 100 MILLIVOLT OUTPUT PRESSURE SENSOR

AVAILABLE IN ABSOLUTE AND GAGE PRESSURE MODELS

15 to 10,000 psi
1 to 690 Bar

PX302/PX312 Series



Product Discontinued

Metric thread adaptors available.



MILLIVOLT OUTPUT
PRESSURE TRANSDUCERS
B

Meter shown slightly smaller than actual size.

Cable style.

PX302-015GV, shown with DP41-S meter, shown actual size.



PX312-100GV, DIN connector included.

- ✓ Rugged All Stainless Steel Construction
- ✓ Integral Strain Relief for Cable or DIN Connector
- ✓ High Sensitivity 10 mV/V Output
- ✓ NEMA 3 Enclosure

SPECIFICATIONS

Excitation: 10 Vdc (5 to 15 Vdc limits)
Output: 10 mV/V ratiometric
 100 mV ±1 mV @ 10 Vdc
Accuracy: 0.25% BFS (linearity, hysteresis, repeatability)
Zero Balance: 0 mV ±2 mV
Input Resistance: 15,000 Ω nominal
Long-Term Stability: ±0.5% full scale
Typical Life: 100 million cycles
Operating Temperature: -18 to 71°C (0 to 160°F)

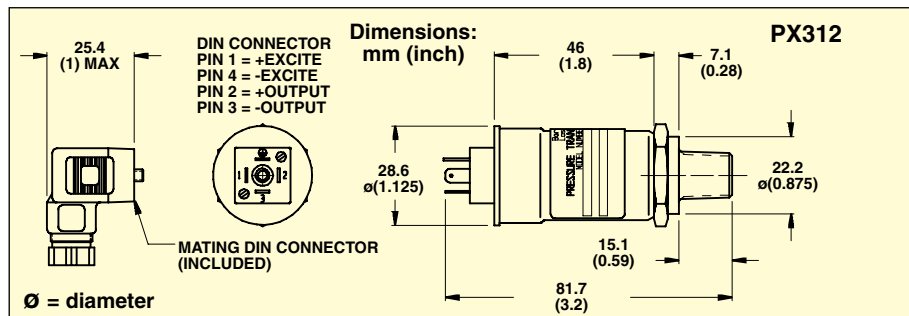
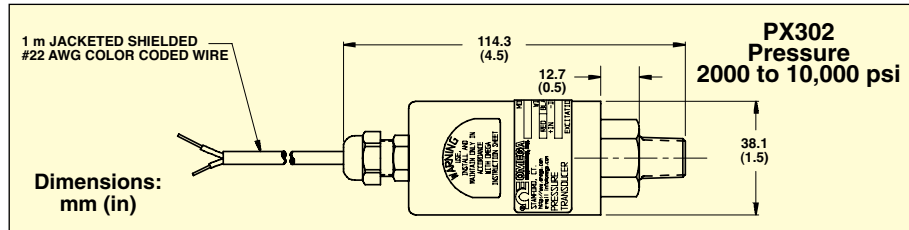
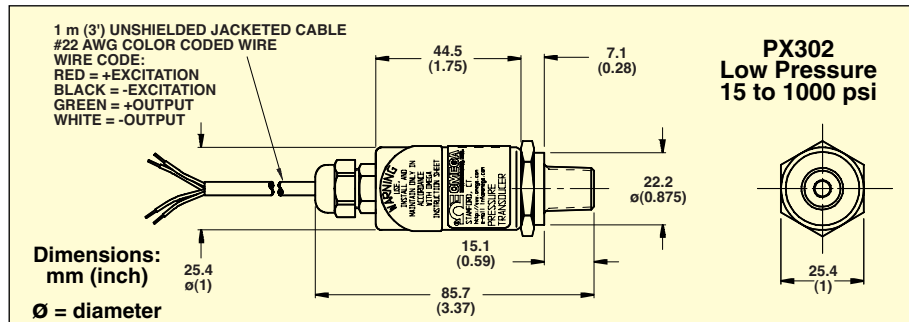

GENERAL PURPOSE PRESSURE SENSOR

Compensated Temperature:

-1 to 71°C (30 to 160°F)

Total Thermal Effects: ±1% FS max

Proof Pressure: 200%, 13,000 psi max

Response Time: 1 ms

Shock: 50 g @ 11 ms

Vibration: 15 g 10 to 2000 Hz

Wetted Parts: 17-4 PH and 300 Series stainless steel

Pressure Port: ¼ NPT male

Electrical Connection:

PX302: 1 m (3') 4-conductor unshielded cable

PX312: mini DIN connector (included)

Weight: 131 g (4.6 oz) to 1000 psi
190 g (6.7 oz) from 1000 psi

PX302-015GV, shown with PS-4G snubber, shown actual size.

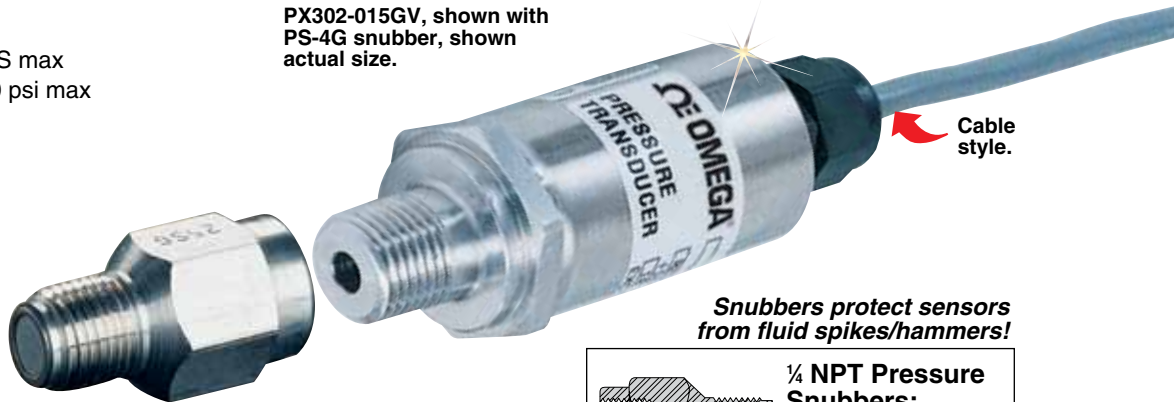

Snubbers protect sensors from fluid spikes/hammers!

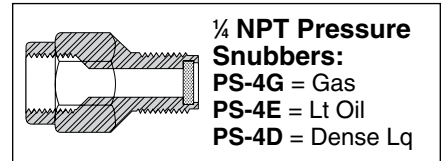

Metric thread adaptors available.

To Order

psi	bar	CABLE STYLE	CONNECTOR STYLE	COMPATIBLE METERS
GAGE PRESSURE RANGES				
0 to 15	0 to 1.0	PX302-015GV	–	DP25B-S, DP41-S, DPiS Series
0 to 30	0 to 2.1	PX302-030GV	–	DP25B-S, DP41-S, DPiS Series
0 to 50	0 to 3.4	PX302-050GV	PX312-050GV	DP25B-S, DP41-S, DPiS Series
0 to 100	0 to 6.9	PX302-100GV	PX312-100GV	DP25B-S, DP41-S, DPiS Series
0 to 200	0 to 13.8	PX302-200GV	–	DP25B-S, DP41-S, DPiS Series
0 to 300	0 to 20.7	PX302-300GV	PX312-300GV	DP25B-S, DP41-S, DPiS Series
0 to 500	0 to 34.5	PX302-500GV	PX312-500GV	DP25B-S, DP41-S, DPiS Series
0 to 1000	0 to 69.0	PX302-1KGV	–	DP25B-S, DP41-S, DPiS Series
0 to 2000	0 to 138	PX302-2KGV	PX312-2KGV	DP25B-S, DP41-S, DPiS Series
0 to 3000	0 to 207	PX302-3KGV	PX312-3KGV	DP25B-S, DP41-S, DPiS Series
0 to 5000	0 to 345	PX302-5KGV	PX312-5KGV	DP25B-S, DP41-S, DPiS Series
0 to 7500	0 to 517	PX302-7.5KGV	–	DP25B-S, DP41-S, DPiS Series
0 to 10,000	0 to 690	PX302-10KGV	PX312-10KGV	DP25B-S, DP41-S, DPiS Series
ABSOLUTE PRESSURE RANGES				
0 to 15	0 to 1.0	PX302-015AV	PX312-015AV	DP25B-S, DP41-S, DPiS Series
0 to 30	0 to 2.1	PX302-030AV	PX312-030AV	DP25B-S, DP41-S, DPiS Series
0 to 50	0 to 3.4	PX302-050AV	PX312-050AV	DP25B-S, DP41-S, DPiS Series
0 to 100	0 to 6.9	PX302-100AV	PX312-100AV	DP25B-S, DP41-S, DPiS Series
0 to 200	0 to 13.8	PX302-200AV	PX312-200AV	DP25B-S, DP41-S, DPiS Series

ACCESSORIES

MODEL NO.	DESCRIPTION
PS-4E	Pressure snubber for water or light oils
PS-4D	Pressure snubber for dense liquids or oils
PS-4G	Pressure snubber for gases and steam

Comes complete with operator's manual.

Ordering Example: PX302-050GV, pressure transducer with 50 psig full scale rating and PS-4E pressure snubber for water and light oils.