

# MINIATURE FLUSH DIAPHRAGM PRESSURE TRANSDUCER

## 1/2-20 UNF PRESSURE CONNECTION

**mV/V Output**  
**0-50 to 0-15,000 psi**  
**0-3 to 0-1000 bar**

**PX61V Series**  
**All Ranges**



Shown larger than actual size.

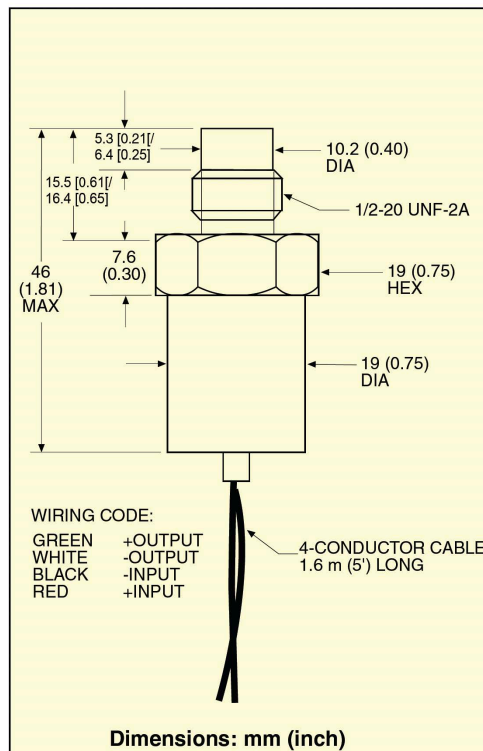

- Miniature Flush Diaphragm
- All Stainless Steel Construction
- Available in psia, psis, psig, and Metric Ranges

### SPECIFICATIONS

**Excitation:** 5 Vdc  
**Output Range:** 2 mV/V -30% +50%  
 (For 50 PSI, 1 mV/V -30% +50%)  
**Accuracy:** 1.0% linearity and hysteresis combined  
**Repeatability:** ±0.1% of FSO  
**Balance:** ±3.0% of FSO  
**Bridge Resistance:** 350 Ω nominal  
**Operating Temperature Range:** -54 to 121°C (-65 to 250°F)  
**Compensated Temperature Range:** 16 to 71°C (60 to 160°F)  
**Thermal Effects:**  
**Zero:** ±0.01% FS/°F  
**Span:** ±0.02% FSO/°F  
**Proof Pressure:** 150% of capacity  
**Burst Pressure Minimum:** 300% of capacity or 30,000 psi, whichever is less  
**Electrical Connections:** 1.5 m (5'); 4-conductor cable or PTIH-10-6P connector  
**Pressure Connection:** 1/2-20 UNF-2A  
**Wetted Parts:** 17-4 PH stainless steel

### ACCESSORY

MODEL NO.	DESCRIPTION
PT06F10-6S	Mating connector for PX61V1series transducers

### To Order

RANGE		MODEL NO.	COMPATIBLE METERS**
<b>ABSOLUTE PRESSURE (All Ranges Available in Absolute Pressure)</b>			
0 to 50 psi	0 to 3.4 bar	PX61V[*]-050AV	DP41-S, DP25B-S
0 to 100 psi	0 to 6.9 bar	PX61V[*]-100AV	DP41-S, DP25B-S
<b>GAGE PRESSURE (All Ranges Also Available in Sealed Gage Pressure)</b>			
0 to 50 psi	0 to 3.4 bar	PX61V[*]-050GV	DP41-S, DP25B-S
0 to 100 psi	0 to 6.9 bar	PX61V[*]-100GV	DP41-S, DP25B-S
0 to 150 psi	0 to 10.3 bar	PX61V[*]-150GV	DP41-S, DP25B-S
0 to 200 psi	0 to 13.8 bar	PX61V[*]-200GV	DP41-S, DP25B-S
0 to 300 psi	0 to 20.7 bar	PX61V[*]-300GV	DP41-S, DP25B-S
0 to 500 psi	0 to 34.5 bar	PX61V[*]-500GV	DP41-S, DP25B-S
0 to 1000 psi	0 to 68.9 bar	PX61V[*]-1KGV	DP41-S, DP25B-S
0 to 2500 psi	0 to 172 bar	PX61V[*]-2.5KGV	DP41-S, DP25B-S
0 to 5000 psi	0 to 345 bar	PX61V[*]-5KGV	DP41-S, DP25B-S
0 to 10,000 psi	0 to 689 bar	PX61V[*]-10KGV	DP41-S, DP25B-S
0 to 15,000 psi	0 to 1034 bar	PX61V[*]-15KGV	DP41-S, DP25B-S†

Comes complete with 5-point NIST-traceable calibration. Metric ranges available – Consult Engineering.

† 4-digit meter, counts in increments of 10.

\*\* Visit us online for compatible meters.

[\*] To order cable style insert "0", to order connector style insert "1".

To order psia models, replace "G" in model number with "A".

To order psis models, replace "G" in model number with "S".

**Ordering Examples:** PX61V0-100AV, 100 psi absolute pressure transducer with 1.5 m (5') cable and 1/2-20 UNF male pressure port.

PX61V0-100SV, 100 psi sealed gage pressure transducer with 1.5 m (5') cable and 1/2-20 UNF male pressure port.



MILLIVOLT OUTPUT  
 PRESSURE TRANSDUCERS  
**B**