

Solid State Relays

Figure 1. Hybrid SSR

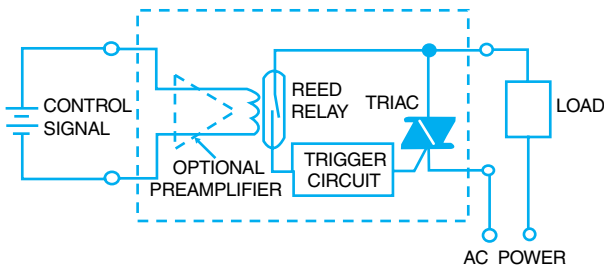

Figure 2. Transformer-Coupled SSR

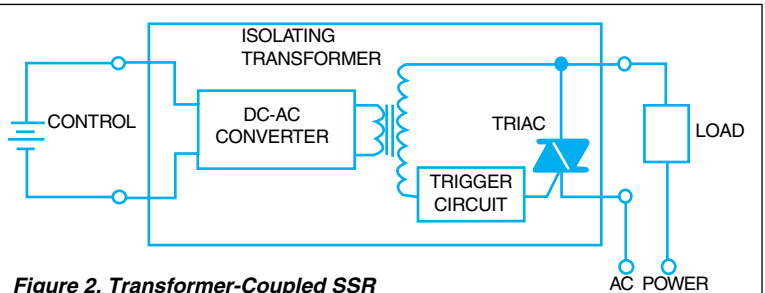
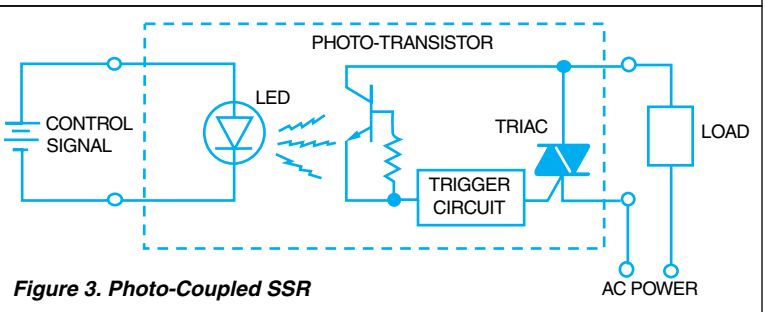

Figure 3. Photo-Coupled SSR



Defined and Described

SSR Defined. A solid-state relay is an ON-OFF control device in which the load current is conducted by one or more *semiconductors* - *e.g.*, a power transistor, an SCR, or a TRIAC. (The SCR and TRIAC are often called “thyristors,” a term derived by combining *thyatron* and *transistor*, since thyristors are *triggered semiconductor switches*.)

Like all relays, the SSR requires relatively low control-circuit energy to switch the output state from OFF to ON, or vice versa. Since this control energy is very much lower than the output power controllable by the relay at full load, “power gain” in an SSR is substantial--frequently much higher than in an electromagnetic relay of comparable output rating. To put it another way, the *sensitivity* of an SSR is often significantly higher than that of an EMR of comparable output rating.

Types of SSR's. It is convenient to classify SSR's by the nature of the input circuit, with particular reference to the means by which input-output isolation is achieved. Three major categories are recognized:

- **Reed-Relay-Coupled SSR's** (see figure 1), in which the control signal is applied (directly, or through a preamplifier) to the coil of a reed relay. The closure of the reed switch then activates appropriate circuitry that triggers the thyristor switch. Clearly, the input-output isolation achieved is that of the reed relay, which is usually excellent.
- **Transformer-Coupled SSR's** (see figure 2), in which the control signal is applied (through a DC-AC converter, if it is DC, or directly, if it is AC) to the primary of a small, low-power transformer, and the secondary voltage that results from the primary excitation is used (with or without rectification, amplification, or other modification) to trigger the thyristor switch. In this type, the degree of input-output isolation depends on the design of the transformer.
- **Photo-coupled SSR's** (see figure 3), in which the con-

trol signal is applied to a light or infrared source (usually, a light-emitting diode, or LED), and the radiation from that source is detected in a photo-sensitive semiconductor (*i.e.*, a photosensitive diode, a photo-sensitive transistor, or a photo-sensitive thyristor). The output of the photo-sensitive device is then used to trigger (gate) the TRIAC or the SCR's that switch the load current. Clearly, the only significant “coupling path” between input and output is the beam of light or infra-red radiation, and electrical isolation is excellent. These SSR's are also referred to as “optically coupled” or “photo-isolated”.

In addition to the major types of SSR's described above, there are some special-purpose designs that should be mentioned:

- **Direct-control AC types** (see figure 4), in which external contacts, operating in a circuit energized by the same AC power line as is used for the load circuit, trigger a TRIAC (or back-to-back-connected SCR's). This type is also referred to as having a “switch closure” input. Clearly, this type of relay, while simpler and inherently less expensive than more sophisticated designs, has the great disadvantage (for most applications) of having no isolation between the control and load circuits.
- **Direct-control DC types** (see figure 5) in which external contacts, operating in a circuit energized by the same DC power line as is used for the load circuit, control the conduction of a transistor. This type of relay, which is perhaps the simplest of all, and inherently the least expensive, also has the great disadvantage (for most applications) of having no isolation between the control and load circuits.
- **SCR types designed for DC**, in which the load-current-carrying SCR is made to turn off by means of a second

Solid State Relays cont'd

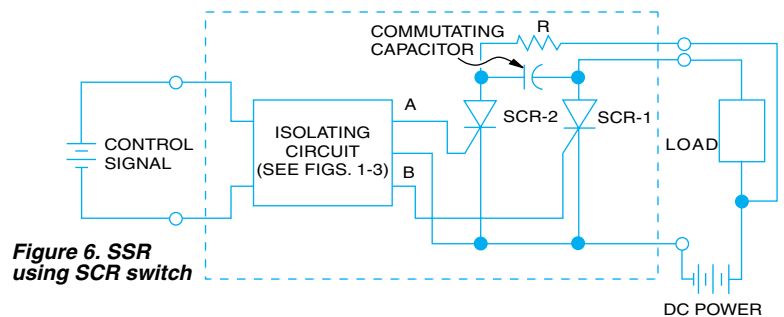
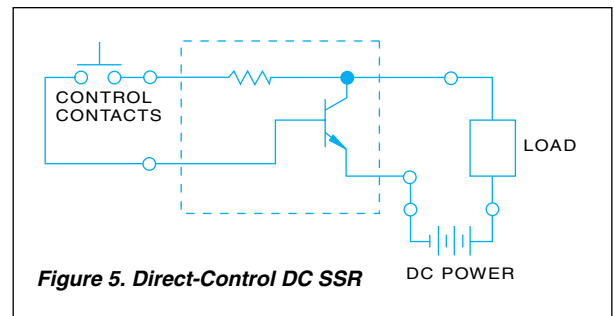
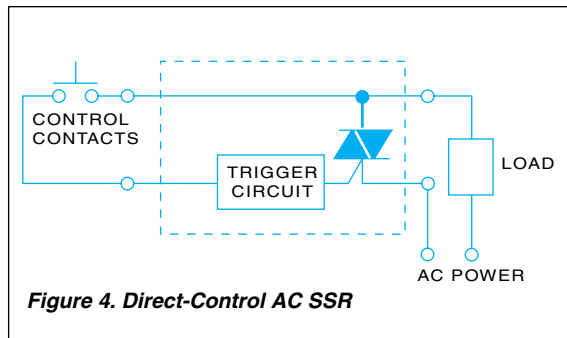

SCR, connected in a “commutating circuit” (such as that of figure 6), which is capable of turning off the first SCR by momentarily reducing its current to zero.

- Designs using special isolating means, such as . . .
 - ...the Hall effect in which the motion of a magnet external to, but in proximity to, the SSR causes a change in resistance in a field-sensitive material, thereby triggering on-off behavior.
 - ...oscillator tuning, in which the external signal shifts the frequency of an oscillator, thereby causing a closely coupled resonant circuit to trigger on-off behavior.
 - ...saturable reactors or magnetic amplifiers, in which a DC control current in one winding controls the induced voltage (from an AC source) in another winding. The induced voltage is then used to trigger on-off behavior.

It is safe to say that well over 95% of all SSR requirements are best satisfied by one of the three major types described earlier (*i.e.*, figures 1-3).

Input Circuit Performance. The sensitivity of **isolated** SSR's (that is, the minimum control voltage and current at which the SSR turns on) depends on the characteristics of the isolating component or circuit:

- In hybrid (reed-relay isolated) designs, the SSR's sensitivity is established by the operating-power requirement of the reed relay, which ranges from as low as 40 milliwatts (*e.g.*, 5 volts dc at 8 mA) to as high as several hundred milliwatts. Note that the low-voltage, low-power designs are compatible with standard digital-computer “logic levels,” and that the standard “high-fan-out” TTL logic-level output from a digital computer or digital controller can drive two or more hybrid SSR's in parallel.
- In transformer-coupled SSR's, the sensitivity is usually considerably higher than that of the hybrid type, because all the input signal must do is to gate on the AC-DC

converter (see figure 2) that drives the transformer, and that requires, typically, less than 10 milliwatts (*e.g.*, 4.5 v dc at 2 mA) and rarely more than 50 milliwatts. This sensitivity is better than required by any single-TTL digital output, and a high-fan-out TTL output can drive from 3 to 10 such SSR's in parallel.

- In optically coupled SSR's, the sensitivity ranges from about 6 milliwatts (*e.g.*, 3 volts dc at 2 mA) to 100 milliwatts. Using an appropriate series resistor or current regulator, this type of input circuit is also compatible with TTL logic levels, and several optically coupled SSR's can be driven in parallel by high-fan-out logic lines.
- The sensitivity of most “direct-control” SSR's (figures 4 and 5) is significantly lower than that of the isolated designs, but that fact is of little importance because the control power required is almost always well within the capability of even the smallest control contacts.

The *maximum* turn-off level (voltage and/or current) of an SSR is about 50% of the *minimum* level at which it turns on. This characteristic provides an adequate margin of safety between the ON and OFF states, thereby eliminating erratic behavior due to small changes in the control signal.

In many SSR designs, the control-voltage *range* is much greater than that implied by the minimum turn-on voltage. In designs optimized for wide input voltage range, it is not uncommon for the SSR to be rated for use over more than a 6-to-1 range of control voltages (*e.g.*, 3.0 V to 32 V). In hybrid designs, the coil of the reed relay may be wound for almost any useful control voltage, from as low as 3 volts nominal, to 50 volts, or even higher, but the *range* of input voltage tolerated by a hybrid SSR is limited by dissipation in the relay coil. Generally, a range of 1.5 to 1 is acceptable. On the other hand, series resistance, or a “constant-current” active input circuit, may be used to accommodate a hybrid relay to higher input voltages.

Figure 7. Simplified Circuit of an SSR (a), and equivalent circuits for the ON state (b) and the OFF state. (c)

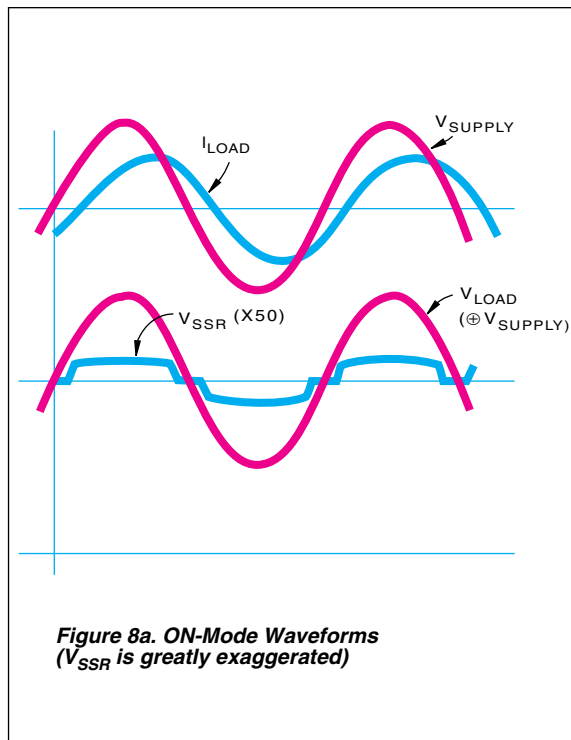

Figure 8a. ON-Mode Waveforms (V_{SSR} is greatly exaggerated)

Input Characteristics. Beyond consideration of the sensitivity characteristics (page Z-120), we must also describe the input-circuit *isolation* characteristics of an SSR, which requires consideration of many different parameters, including:

- **Dielectric strength**, rated in terms of minimum breakdown voltage from control circuit to both the SSR case and the output (load) circuit. A typical rating is 1500 volts ac (RMS), for either control to case or control to output.
- **Insulation Resistance**, from control circuit to both the case and the output circuit. Typical ratings range from 10 megohms to 100,000 megohms for transformer and hybrid designs. For optically isolated SSR's, typical insulation resistances range from 1000 to 1 million megohms.
- **Stray Capacitance** from control circuit to both case and the output circuit. Capacitance to case is rarely significant, but capacitance to the output circuit may couple ac and transients back to the sensitive control circuit, and even further back, into the control-signal sources. Fortunately, in well designed SSR's, this capacitance is rarely large enough to cause interaction. Typical stray capacitance ranges from 1 to 10 picofarads.

The speed of response of the SSR to the application of control voltage is covered later in this section.

Output Circuit Performance. Clearly, the most significant output-circuit parameters are the maximum load-circuit voltage that may be impressed across the relay output circuit in the OFF condition without causing it to break down into conduction or failure, and the maximum current that can flow through the output circuit and load in ON condition.

Note that these parameters are (at least at first glance) analogous to the usual voltage and current ratings of the contacts on an electro-magnetic relay. There are, however, differences between EMR output ratings and SSR output ratings--differences that will be examined in detail as this exposition proceeds.

In the most general approach, one may say that the "contact ratings" of an SSR are determined almost entirely by the characteristics of the load-current switching device. Perhaps this fact is most apparent from an examination of the simplest type of ac SSR - a direct-control (non-isolated) design, such as that originally shown in figure 4, and redrawn above in figure 7, with its equivalent circuit for both the ON and OFF states. In the ON state (figure 7b), the TRIAC exhibits a nearly constant voltage drop (*i.e.*, almost independent of load current) approximately equal to that of two silicon diodes - less than 2 volts. The passage of load current through this voltage drop causes power dissipation ($P_d = V_d \times I_{load}$), and this power will cause a temperature rise in the TRIAC junction. If proper "heat-sinking" is provided - *i.e.*, thermal conduction from the TRIAC case to the outside air or to a heat-conductive metal structure that can in turn dissipate the power to the surrounding air without significant temperature rise - then the TRIAC temperature will not rise above the rated maximum value for reliable operation (typically, 100°C). With *generous* heat sinking, the current rating of the SSR may be determined, not by power dissipation, but by the current rating of the TRIAC.

Figure 7c shows the equivalent circuit of this very simple SSR in the OFF state. Note that even when the TRIAC is turned off, a very small amount of leakage current can flow. This current path, represented by a resistance in the equivalent circuit, is actually a non-linear function of the load-circuit voltage. The normal practice, in rating

Solid State Relays cont'd

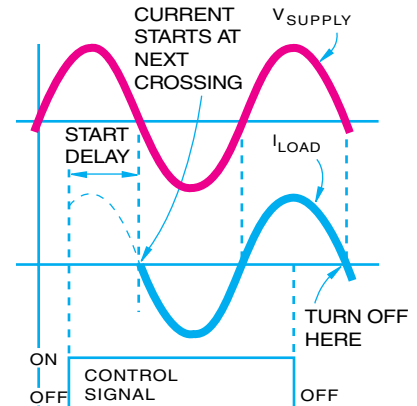
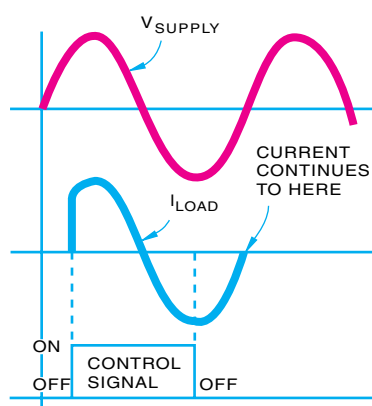
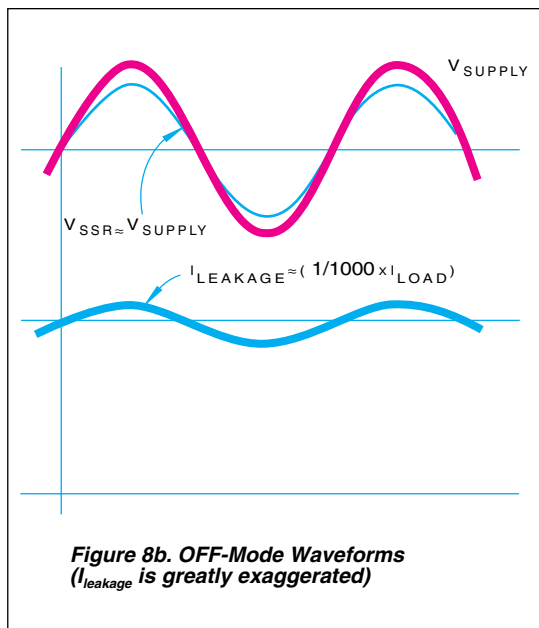

TRIAC's, is to specify a worst case maximum value for this "OFF-state leakage" and a typical value is 0.001 A max. for a 5-ampere load-current rating. The load circuit voltage rating is simply that determined by the blocking voltage rating of the thyristor.

The output-circuit ratings of the more common isolated SSR's, most of which are designed to control ac load circuits, are very similar to those described above, except that OFF-state leakage is usually higher---on the order of 5 mA at 140 V for a 5-ampere device---still only about one-thousandth of the load current rating. Figure 7 shows the equivalent circuit of a TRIAC-switch SSR design, and figure 8 shows the voltage and current waveforms in the load circuit, for both OFF and ON states. Note that the ON-state voltage-drop curves are drawn to a much expanded scale compared with the OFF state and load voltage curves.

Even at this early stage in our examination of SSR performance, it is necessary to consider the *time* relationships between the control signal and the ac load-circuit voltage and current.

With respect to timing, there are two classes of switching SSR's. In one, no particular effort is made to achieve synchronism between the alternations of the load circuit-power line and the turning on of the thyristor switch. In this "non-synchronous" class, then, the response delay between the application of control voltage and the beginning of load-circuit conduction is very short...typically from 20 to 200 microseconds in optically coupled and transformer types, and less than one millisecond in hybrids (longer due to the reed relay operation time). The current waveform on turn-on in non-synchronous designs is clearly a function of when in the ac cycle the control signal is applied, as illustrated in figure 9a.

In *synchronous* (zero-voltage turn-on) designs, the

effect of the application of a control signal is delayed (if necessary) until the power-line voltage is passing through zero (see figure 9b). (This is done by internal gating circuitry that senses the magnitude of the line voltage, and prevents triggering the thyristor until the next zero crossing occurs.) Thus, if the control signal happens to be applied immediately *after* a zero crossing, the SSR would not actually begin conducting until almost a full half-cycle later. On the other hand, if the control signal happens to be applied just *before* a zero-crossing is about to occur, the SSR would begin to conduct almost immediately, with only the very small turn-on delays described above for *non-synchronous* designs. Clearly, then, the turn-on delay of a synchronous SSR can have any value from less than a millisecond to a full half-cycle of the power line (about 8.3 milliseconds for a 60-Hz power line). Usually, for 60 Hz service, the rating is given as 8.3 milliseconds maximum for all-solid-state designs, and 1.5 milliseconds maximum for hybrid designs.

The final major characteristic of the AC-switching SSR is its turn-off behavior. Because a thyristor, once triggered, will not stop conducting until the load current flowing through it falls to zero, there is a maximum possible turn-off delay (between the removal of the control signal and the cessation of load current) of one half cycle. As in the case of turn-on, the *minimum* turn-off delay is close to zero. Thus, a typical 60-Hz rating for turn-off time is 9 milliseconds maximum.

