

1/16 DIN Limit Controller

CN6221 Series



- ✓ Dual Display
- ✓ Universal Input
- ✓ High or Low Limit
- ✓ Digital Input for Remote Reset
- ✓ RS485 Communications (Optional)
- ✓ Alarms (Optional)
- ✓ Retransmission Output (Optional)

The CN6221 Series is an FM approved limit controller that can be configured either as a high limit or as a low limit controller. The CN6221 features universal input, 2 alarm outputs, retransmission output, a timer to count the total time the setpoint is exceeded, and a register to retain the maximum. The RS485 communication interface is available as an option.

Specifications

Power Supply
Voltage: 100 to 240 Vac ($\pm 10\%$),
Frequency: 50 or 60 Hz
Maximum Power Consumption:
 8 Va max (4 W maximum)
Memory: Non-volatile memory
Withstanding Voltage (Between Primary and Secondary Terminals):
 1500 Vac for 1 min (see Note 1)
Insulation Resistance (Between Primary and Secondary Terminals):
 20 M Ω or more at 500 Vdc (see Note 1)
Note 1: The primary terminals are the power supply terminals and relay output terminals. The secondary terminals are the analog input and output terminals, the voltage pulse output terminals, and the contact input terminals.
Contact Input
Function: Resetting "exceeded status"
Input: 1 point
Type: Non-voltage contact or transistor contact
Contact Capacity: At least 12V/10 mA
On/Off Judgment: On state for 1 k Ω or less; off state for 20 k Ω or greater



CN6221-R shown smaller than actual size.

Measured Value (PV)

Input: 1 point
Type: Universal; selectable by software
Accuracy (At $\pm 2^\circ\text{C}$ Ambient Temperature):
Thermocouple: $\pm 2^\circ\text{C} \pm 1$ digit
At -200 to -100°C : $\pm 4^\circ\text{C}$
At -100 to 0°C : $\pm 3^\circ\text{C}$
Types R and S: $\pm 5^\circ\text{C}$ [$\pm 9^\circ\text{C}$ for 0 to 500°C (32 to 932°F)]
Type B: $\pm 9^\circ\text{C}$ (accuracy is not guaranteed for 0 to 400°C)
RTD: $\pm 1^\circ\text{C} \pm 1$ digit
Voltage (mV, V): $\pm 0.3\% \pm 1$ digit
Sampling Period for Measured Value
Input: 500 ms

Burn-Out Detection: Functions for thermocouple or RTD input (burn-out upscale only; cannot be switched off)
Input Resistance: 1 M Ω or greater for thermocouple or DC mV inputs; approximately 1 M Ω for DC V input
Maximum Allowable Signal Source Resistance: 250 Ω for thermocouple or DC mV input; 2 k Ω for DC V input
Maximum Allowable Wiring Resistance for RTD Input: 10 Ω /wire (resistance values of 3 wires must be the same)
Allowable Input Voltage: ± 10 Vdc for thermocouple or DC mV input; ± 20 Vdc for DC V input

Input Table

Input Type		Range ($^\circ\text{C}$)	Range ($^\circ\text{F}$)
Thermocouple	K	-270 to 1370	-300 to 2500
		0 to 600	32 to 999.9
		0 to 400	32 to 750
	J	-199.9 to 200	-300 to 400
		-199.9 to 999.9	-300 to 2100
		-199.9 to 400	-300 to 750
		-199.9 to 999.9	-300 to 1800
		0 to 1700	32 to 3100
		0 to 1700	32 to 3100
		0 to 1800	32 to 3200
		-200 to 1300	-300 to 2400
		-199.9 to 900	-300 to 1600
-199.9 to 400	-300 to 750		
Platinel 2	0 to 1390	32 to 2500	
RTD	Pt100	-199.9 to 850	-199.9 to 999.9
		0 to 400	32 to 750
		-199.9 to 200	-300 to 400
		-19.9 to 99.9	-199.9 to 999.9
		-199.9 to 500	
DC Voltage	JPt100	0 to 100 mV	0 to 100
		0 to 5V	0 to 5
		1 to 5V	1 to 5
		0 to 10V	0 to 10

Noise Rejection Ratio:

Normal Mode Noise: Minimum 40 dB (50/60 Hz)

Common Mode Noise: Minimum 120 dB (90 dB for DC V input)

Reference Junction Error

Compensation: $\pm 1.5^{\circ}\text{C}$ (at 15 to 35°C), $\pm 2.0^{\circ}\text{C}$ (at 0 to 50°C)

Note: The reference junction compensation cannot be switched off

Applicable Standards: RTD, Thermocouple, JIS/IEC/DIN (ITS90)

Control Output

Output: 1 point

Type: Relay contact

Contact Capacity: 3 A @ 240 Vac or 3 A @ 30 Vdc (with resistance load)

Note: The control output relay cannot be replaced by users.

Alarm Functions (Optional)

Alarm Types: 22 types (waiting action can be set by software): PV high-limit, PV low-limit, deviation high-limit, deviation low-limit, de-energized on deviation highlimit, deenergized on deviation low-limit, deviation high- and low-limits, high- and low-limits within deviation, de-energized on PV high-limit, de-energized on PV low-limit, fault diagnosis output, fail output

Alarm Output: 2 relay contacts

Relay Contact Capacity: 1 A @ 240 Vac or 1 A @ 30 Vdc (with resistance load)

Note: The alarm output relays cannot be replaced by users.

Retransmission Output (Optional)

The retransmission output is provided only when the "/RET" option is specified.

Output Signal: Measured value in 4 to 20 mAdc

Maximum Load Resistance: 600Ω

Output Accuracy: $\pm 0.3\%$ of span (at $23 \pm 2^{\circ}\text{C}$ ambient temperature)

Communication Interface

Applicable Standards: Complies with EIA RS485

Number of Controllers: Up to 31

Maximum Communication Distance: 1200 m (3937')

Communication Method: 2-wire half-duplex, start-stop synchronization, non-procedural

Construction, Mounting, and Wiring Construction: Dust-proof and drip-proof front panel conforming to IP65; for side-by-side close installation, controller loses its dust-proof and drip-proof protection

Casing: ABS resin and polycarbonate

Case Color: Black

Mounting: Flush panel mounting

Environmental Conditions

Normal Operating Conditions

Warm-Up Time: At least 30 minutes

Ambient Temperature: 0 to 50°C (0 to 40°C when mounted side-by-side)

Rate of Change of Temperature: $10^{\circ}\text{C}/\text{h}$ or less

Ambient Humidity: 20 to 90% RH (no condensation allowed)

Magnetic Field: 400 A/m or less

Continuous Vibrations of 5 to 14 Hz: Amplitude of 1.2 mm or less

Continuous Vibrations of 14 to 150 Hz: 4.9 m/s^2 (0.5 G) or less

Short-Period Vibrations: 14.7 m/s^2 (1.5 G) for 15 seconds or less

Shock: 98 m/s^2 (10 G) for 11 ms or less

Mounting Angle: Upward incline of up to 30 degrees; no downward incline

Altitude: ≤ 2000 m above sea level

Maximum Effects from Operating Conditions

Temperature Effects

Thermocouple, mVdc and Vdc

Inputs: $\pm 2 \mu\text{V}/^{\circ}\text{C}$ or $\pm 0.02\%$ of FS/ $^{\circ}\text{C}$, whichever is the larger

Resistance Temperature Detector: $\pm 0.05^{\circ}\text{C}/^{\circ}\text{C}$

Analog Output: $\pm 0.05\%$ of FS/ $^{\circ}\text{C}$

Effect from Fluctuation of Power Supply Voltage (Within Rated Voltage Range)

Analog Input: $\pm 0.2 \mu\text{V}/\text{V}$ or $\pm 0.002\%$ of FS/V, whichever is larger

Analog Output: $\pm 0.05\%$ of FS/V

Transportation and Storage Conditions

Temperature: -25 to 70°C (-13 to 158°F)

Humidity: 5 to 95% RH (no condensation allowed)

Shock: Package drop height 90 cm (35") (when packed in the dedicated package)

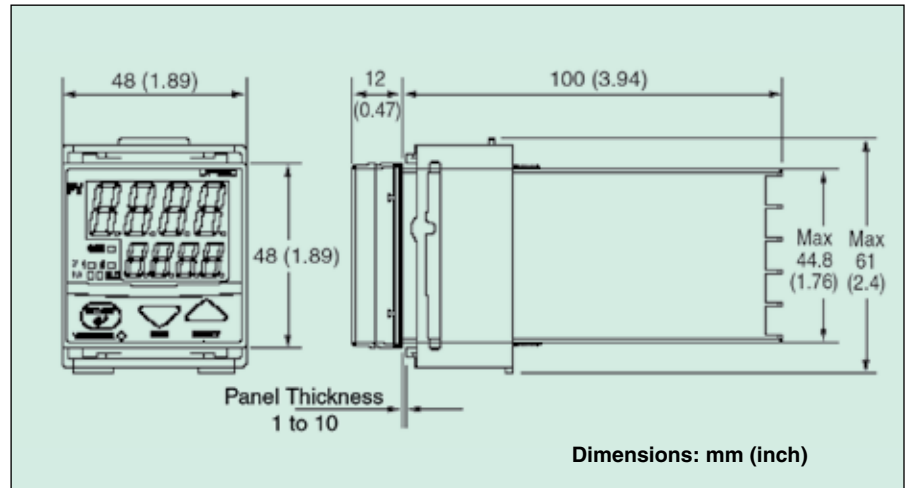

To Order

Model No.	Description
CN6221-R	Limit controller, single relay output

Options

Ordering Suffix	Description
-AL	Dual alarms
-PV	4 to 20 mA retransmission output
-C4*	RS485 communications
-DI *	Digital input switching

* Only one option can be ordered.

Accessories (Field Installable)

Model No.	Description
CNQUENCHARC	Noise suppression kit, 110 to 230 Vac
DPP-4	$\frac{1}{16}$ DIN panel punch

Comes complete with operator's manual.

Ordering Example: CN6221-R-C4, single output limit controller, mechanical relay, RS485 communications.