

Freezer Series | Platinum RTD

Remote Freezer, Platinum RTD



Automation Components
a DwyerOmega brand

The ACI RTD Freezer Series features a 4.76 mm (3/16 in) diameter stainless steel probe with a 3.05 m (10 ft) or 9.14 m (30 ft), 3 Conductor, 0.51 mm (24 AWG) Plenum rated jacketed Teflon cable. The sensors in this series are manufactured using ACI's proven encapsulation process to eliminate the effects of moisture upon the sensors. The sensor is designed to be used in Pharmaceutical, Liquid Nitrogen, Freezers, Refrigerators and Hydronic applications where a remote sensor is required due to the extreme temperature ranges and presence of ice and moisture. An optional "-GD" galvanized or "-4X" NEMA 4X weather proof enclosure and NIST Certificates are available as referenced in the ordering grid on the product data sheet. The Freezer RTD sensors can be used with any of the Single or Triple Point Thermal Buffers for when slower response time is desired.

Applications

Pharmaceutical, Liquid Nitrogen, Refrigerators, Freezers, Hydronic Heating, Remote Sensor Applications, Hospital, Agricultural

Warranty

The ACI RTD Platinum Freezer Series is covered by ACI's Five (5) Year Limited Warranty. The warranty can be found in the front of ACI's Sensors & Transmitters catalog, as well as on ACI's website, workaci.com.

Specifications

Sensor Type: Platinum RTD

Sensor Curve: PTC (Positive Temperature Coefficient)

Number Sensing Points: One

Number Wires: Three Conductors (White and Two Red Wires); Polarity Sensitive (Tie Red wires together)

Sensor Output at 0 °C (32 °F)

A/100-LTS Series: 100 Ω nominal

A/1K-LTS Series: 1000 Ω nominal

Sensor Tolerance Class

Class B Accuracy Formula: $\pm \text{ }^\circ\text{C} = (\pm 0.30 \text{ }^\circ\text{C} + (0.005 \times |t|))$ where t is the Absolute Value of temperature in °C above or below 0 °C

-200°C (-328°F): $\pm 1.30 \text{ }^\circ\text{C} (\pm 2.34 \text{ }^\circ\text{F})$

0°C (-32°F): $\pm 0.30 \text{ }^\circ\text{C} (\pm 0.54 \text{ }^\circ\text{F})$

Din Standard: DIN EN 60751 (IEC 751)

Temperature Coefficient: 3850 ppm / °C

Response Time (63 % Step Change)

A/100-LTS Series: In still air: 3:40 (minutes:seconds)

In water: 19 seconds

A/1K-LTS Series: In still air: 3:50 (minutes:seconds)

In water: 22 seconds

Sensor Operating Temperature Range: -198 °C to 150 °C (-324 °F to 302 °F)

Enclosure Operating Temperature Range

"-GD" Enclosure: -40 °C to 100 °C (-40 °F to 212 °F)

"-4X" Enclosure: -40 °C to 70 °C (-40 °F to 158 °F)

Storage Temperature Range: -40 °C to 80 °C (-40 °F to 176 °F)

Operating Humidity Range: 10 % to 100 % RH



Enclosure Material | Flammability Rating

"-GD" Enclosure: Galvanized Steel

"-4X" Enclosure: Polystyrene I UL94-V2

Enclosure NEMA/IP Ratings

"-GD" Enclosure: NEMA 1 (IP10)

"-4X" Enclosure: NEMA 4X (IP 66)

Cable Gland (Fitting) Size | Hole Size: PG7 I 15 mm (0.591 in)

Cable Gland Material | Sleeve Material: Polyamide 6 I Neoprene

Cable Gland Wire Clamping Size | IP Rating: 2.5 mm (0.098 in) to 6.5 mm (0.256 in) I IP 68 (NEMA 6P)

Cable Gland Torque Rating: 2.5 Nm (22.127 lb-in)

Probe Material | Length | Diameter: 316 Stainless Steel I 50.8 mm (2 in) I 4.76 mm (0.1875 in) nominal

Lead Length | Cable Diameter: 3.05 m (10 ft) or 9.15 m (30 ft) I 2.69 mm (0.106 in) nominal

Conductor Size | Conductor Material: 0.51 mm (24 AWG) I Silver Plated Copper

Lead Wire Insulation | Jacket Color: FEP/FEP (Teflon) Jacketed Cable I White

Product Weight

A/xx-LTS-10': 0.073 kg (0.16 lb)

A/xx-LTS-4X-10': 0.181 kg (0.40 lb)

A/xx-LTS-GD-10': 0.322 kg (0.71 lb)

A/xx-LTS-30': 0.163 kg (0.36 lb)

A/xx-LTS-4X-30': 0.272 kg (0.60 lb)

A/xx-LTS-GD-30': 0.413 kg (0.91 lb)

Agency Approvals: CE, UKCA, WEEE, RoHS3

Dimensions



Automation Components
a DwyerOmega brand

NEMA 4X Enclosure (4X)

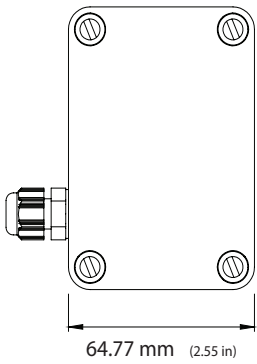

Front View

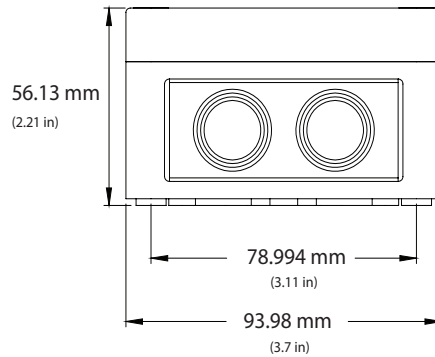

Side View

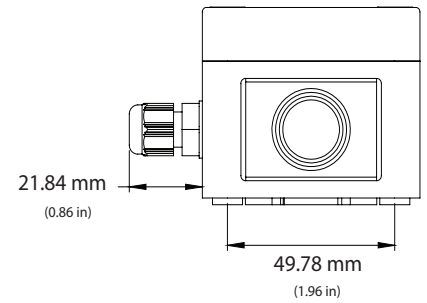

Top View

Galvanized Enclosure (GD)

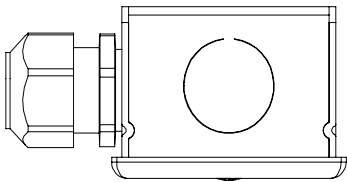

Front View

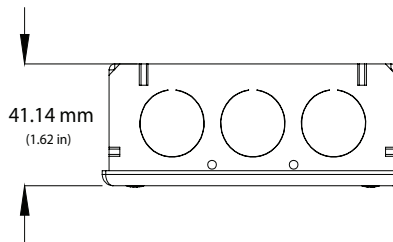

Side View

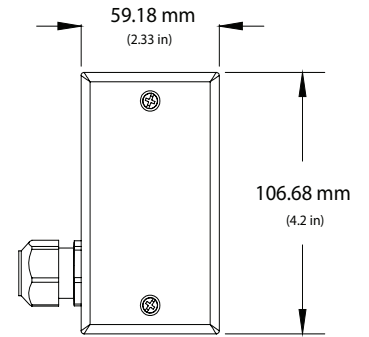

Top View

Sensor Probe



Front View

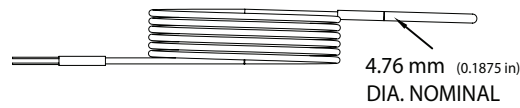

Side View

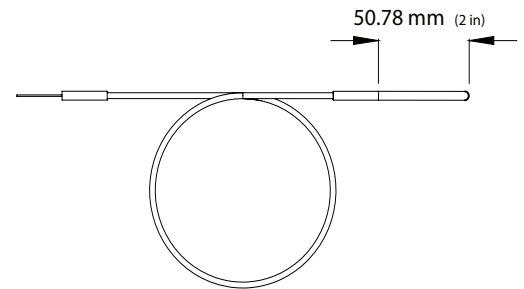

Top View



Standard Ordering

Model #	Item #	Description
A/100-LTS-10'	125169	100 Ω RTD, 50.8 mm (2 in) Probe, Freezer Sensor, 3.05 m (10 ft) Leads
A/100-LTS-GD-10'	142513	100 Ω RTD, 50.8 mm (2 in) Probe, Freezer Sensor, 3.05 m (10 ft) Leads, Galvanized Enclosure
A/100-LTS-4X-10'	142515	100 Ω RTD, 50.8 mm (2 in) Probe, Freezer Sensor, 3.05 m (10 ft) Leads; NEMA 4X Enclosure
A/100-LTS-30'	126443	100 Ω RTD, 50.8 mm (2 in) Probe, Freezer Sensor, 9.15 m (30 ft) Leads
A/100-LTS-GD-30'	142514	100 Ω RTD, 50.8 mm (2 in) Probe, Freezer Sensor, 9.15 m (30 ft) Leads, Galvanized Enclosure
A/100-LTS-4X-30'	129131	100 Ω RTD, 50.8 mm (2 in) Probe, Freezer Sensor, 9.15 m (30 ft) Leads; NEMA 4X Enclosure
A/1K-LTS-10'	125213	1 k Ω RTD, 50.8 mm (2 in) Probe, Freezer Sensor, 3.05 m (10 ft) Leads
A/1K-LTS-GD-10'	142139	1 k Ω RTD, 50.8 mm (2 in) Probe, Freezer Sensor, 3.05 m (10 ft) Leads, Galvanized Enclosure
A/1K-LTS-4X-10'	133656	1 k Ω RTD, 50.8 mm (2 in) Probe, Freezer Sensor, 3.05 m (10 ft) Leads; NEMA 4X Enclosure
A/1K-LTS-30'	125214	1 k Ω RTD, 50.8 mm (2 in) Probe, Freezer Sensor, 9.15 m (30 ft) Leads
A/1K-LTS-GD-30'	142516	1 k Ω RTD, 50.8 mm (2 in) Probe, Freezer Sensor, 9.15 m (30 ft) Leads, Galvanized Enclosure
A/1K-LTS-4X-30'	125212	1 k Ω RTD, 50.8 mm (2 in) Probe, Freezer Sensor, 9.15 m (30 ft) Leads, NEMA 4X Enclosure

Model # Example: **A/1K-LTS-GD-30'** or **142516**

Optional Sensor Ordering

	Options and Descriptions	Model #
A. Sensor Series <i>No Selection Required</i>	A/ \longrightarrow	A/
B. Model Series <i>Select One (1)</i>	100 = 100 Ω Platinum RTD 1K = 1 k Ω Platinum RTD	
C. Configuration <i>No Selection Required</i>	LTS = Freezer Sensor \longrightarrow	LTS
D. Enclosure <i>Select One (1)</i>	---- = No Enclosure GD = Galvanized Enclosure 4X = NEMA 4X Enclosure	
E. Lead Length <i>Select One (1)</i>	10' = 3.05 m (10 ft) leads 30' = 9.15 m (30 ft) leads	
F. NIST <i>Select One (1)</i>	---- = No NIST Certificate NIST = NIST Certificate (3 Points)	

Model # Example:

A/	1K	LTS	4X	30'	NIST
A.	B.	C.	D.	E.	F.



Accessories Ordering

Model #	Item #	Description
A/TB-2.0-GLA	147220	Thermal Buffer, 67 ml (2 oz) Nalgene Bottle, 1 Sensing Point, Mounting Bracket, Glass Beads, Rated to -100 °C
A/TB-2.0-GLY	147221	Thermal Buffer, 67 ml (2 oz) Nalgene Bottle, 1 Sensing Point, Mounting Bracket, Food Grade Glycol, Rated to -40 °C
A/TB-2.0-XXY	147222	Thermal Buffer, 67 ml (2 oz) Nalgene Bottle, 1 Sensing Point, Mounting Bracket, Empty Bottle, Polyamide Fitting, Rated to -40 °C
A/TB-2.0-XXA	147653	Thermal Buffer, 67 ml (2 oz) Nalgene Bottle, 1 Sensing Point, Mounting Bracket, Empty Bottle, SS Fitting, Rated to -100 °C
A/TB-8.5-1-GLA	147223	Thermal Buffer, 250 ml (8.5 oz) Nalgene Bottle, 1 Sensing Point, Mounting Bracket, Glass Beads, Rated to -100 °C
A/TB-8.5-1-GLY	147225	Thermal Buffer, 250 ml (8.5 oz) Nalgene Bottle, 1 Sensing Point, Mounting Bracket, Food Grade Glycol, Rated to -40 °C
A/TB-8.5-1-XXX	147226	Thermal Buffer, 250 ml (8.5 oz) Nalgene Bottle, 1 Sensing Point, Mounting Bracket, Empty Bottle, Rated to -100 °C
A/TB-8.5-3-GLA	147227	Thermal Buffer, 250 ml (8.5 oz) Nalgene Bottle, 3 Sensing Points, Mounting Bracket, Glass Beads, Rated to -100 °C
A/TB-8.5-3-GLY	147228	Thermal Buffer, 250 ml (8.5 oz) Nalgene Bottle, 3 Sensing Points, Mounting Bracket, Food Grade Glycol, Rated to -40 °C
A/TB-8.5-3-XXX	147229	Thermal Buffer, 250 ml (8.5 oz) Nalgene Bottle, 3 Sensing Points, Mounting Bracket, Empty Bottle, Rated to -100 °C
A/GLYCOL 250ML	144021	Glycol Filled Bottle (250 ml)
A/GLA 250ML	147328	Glass Bead Filled Bottle (250 ml)

Note: 2.0 (2 oz) models are shipped with the original lid in place along with an additional lid drilled out with the sensor cord grip.



Freezer Series I Transmitters

Remote Freezer Transmitters



Automation Components
a DwyerOmega brand

The ACI RTD Freezer Series features a 4.76 mm (3/16 in) diameter stainless steel probe with a 3.05 m (10 ft) or 9.14 m (30 ft), 3 Conductor, 0.51 mm (24 AWG) Plenum rated jacketed Teflon cable. The sensor is designed to be used in Pharmaceutical, Liquid Nitrogen, Freezers, Refrigerators and Hydronic applications where a remote sensor is required. Optional “-GD” galvanized, “-BB” Aluminum, or “-4x” NEMA 4X weather proof plastic enclosures are available as well as NIST Certificates as referenced on the back of the product data sheet. A/TT Series transmitter accuracies must be calculated using both the calibration accuracy of the transmitter and the sensor accuracy over your applications operating temperature range. For higher accuracies, the A/TTM Series includes a secondary calibration process designed to eliminate most of the sensor error from the overall system accuracy. Any Freezer Transmitter can be used with the Single or Triple Point Glycol Kits when a Thermal Buffer (slower) response time is desired.

Applications

Pharmaceutical, Liquid Nitrogen, Refrigerators, Freezers, Hydronic Heating, Remote Sensor Applications, Hospital, Agricultural

Warranty

The ACI Transmitter Freezer Series is covered by ACI's Five (5) Year Limited Warranty. The warranty can be found in the front of ACI's Sensors & Transmitters catalog, as well as on ACI's website, workaci.com.

Specifications

Transmitter Supply Voltage | Supply Current: 8.5 V dc to 32 V dc (Reverse Polarity Protected) | 25 mA minimum

250 Ω Load: 13.5 V dc to 32 V dc

500 Ω Load: 18.5 V dc to 32 V dc

Maximum Load Resistance: Terminal Voltage - 8.5 V | 0.020 A | (775 Ω @ 24 V dc)

Output Signals

Current: 4 mA to 20 mA (2-Wire Loop Powered)

Voltage: 1 V dc to 5 V dc or 2 V dc to 10 V dc (3-Wires)

Calibrated Transmitter Accuracy | Linearity

Temp. Spans < 260 °C (500 °F): ± 0.2 %

Temp. Spans > 260 °C (500 °F): ± 0.5 %

Temperature Drift

Temp. Spans < 38 °C (100 °F): ± 0.04 % / °F

Temp. Spans > 38 °C (100 °F): ± 0.02 % / °F

TTM100/TTM1K Certification Points

3 Point NIST: 20 %, 50 % & 80 % of span

5 Point NIST: 20 %, 35 %, 50 %, 65 %, 80 % of span

Warm Up Time | Warm Up Drift: 10 Minutes | ± 0.1 %

Operating | Storage Temperature Range: -40 °C to 85 °C (-40 °F to 185 °F)

Operating Humidity Range: 0 % to 95%, non-condensing

Calibrated Temperature Spans¹

Minimum Temp. Span: 28 °C (50 °F)

Maximum Temp. Span: 538 °C (1000 °F)

Matched Calibrated Temperature Spans (A/TTM models)

Range: -45 °C to 155 °C (-49 °F to 311 °F)



Connections | Wire Size: Screw Terminal Blocks (Polarity Sensitive) | 1.31 mm² (16 AWG) to 0.129 mm² (26 AWG)

Terminal Block Torque Rating: 0.5 Nm nominal

Sensor Type | Sensor Curve: Platinum RTD | Linear, PTC (Positive Temperature Coefficient)

Number Wires: Three Conductors (White and Two Red Wires); Polarity Sensitive (Red wires tied together)

Sensor Output @ 0 °C (32 °F)

A/TT/TTM100-LTS Series: 100 Ω nominal

A/TT/TTM1K-LTS Series: 1000 Ω nominal

RTD Tolerance Class² | Sensory Accuracy

Class B | **Accuracy Formula:** ± °C = (± 0.30 °C + (0.005 × |t|))

-200 °C (-328 °F): ± 1.30°C (± 2.43 °F)

0 °C (-32 °F): ± 0.30 °C (± 0.54 °F)

Response Time (63% Step Change)

A/TT/TTM100-LTS Series: In still air: 3:40 (minutes:seconds) In water: 19 seconds

A/TT/TTM1K-LTS Series: In still air: 3:50 (minutes:seconds) In water: 22 seconds

Temperature Coefficient | Din Standard: 3850 ppm / °C | DIN EN 60751 (IEC 751)

Stability: < 0.04 % at 1000 hours at 400 °C (752 °F)

Sensor Operating Temperature Range: -198 °C to 150 °C (-324 °F to 302 °F)

Enclosure Specifications (Operating Temperature, Material, Flammability, NEMA/IP Ratings)

“-GD” Enclosure: -40 °C to 121 °C (-40 °F to 250 °F); Galvanized Steel; NEMA 1 (IP10)

“-BB” Enclosure: Aluminum, -40 °C to 121 °C (-40 °F to 250 °F), Plenum Rated, NEMA 3R (IP 14)

“-4X” Enclosure: -40 °C to 70 °C (-40 °F to 158 °F); Polystyrene Plastic; UL94-V2; NEMA 4X (IP 66)

Storage Temperature Range: -40 °C to 80 °C (-40 °F to 176 °F)

Cable Gland (Fitting) Size | Hole Size | Material: PG7 | 15 mm (0.591 in) | Polyamide 6

Cable Gland Sleeve Material | Wire Clamping Size: Neoprene | 2.5 mm (0.098 in) to 6.5 mm (0.256 in)

Cable Gland IP Rating | Torque Rating: IP 68 (NEMA 6P) | 2.5 Nm (22.127 lb-in)

Probe Material | Length | Diameter: 316 Stainless Steel | 50.8 mm (2 in) | 4.76 mm (0.1875 in) nominal

Lead Length | Cable Diameter: 3.05 m (10 ft) or 9.15 m (30 ft) | 2.69 mm (0.106 in) nominal

Conductor Size | Conductor Material: 0.51 mm (24 AWG) | Silver Plated Copper

Lead Wire Insulation | Jacket Color: FEP/FEP (Teflon) Jacketed Cable | White

Product Weights

A/TT/TTMxxx-LTS-BB-10': 0.39 kg (0.84 lb)



Automation Components
a DwyerOmega brand

A/TT/TTMxxx-LTS-4X-10': 0.19 kg (0.42 lb)

A/TT/TTMxxx-LTS-GD-10': 0.32 kg (0.73 lb)

A/TT/TTMxxx-LTS-BB-30': 0.48 kg (1.04 lb)

A/TT/TTMxxx-LTS-4X-30': 0.29 kg (0.62 lb)

A/TT/TTMxxx-LTS-GD-30': 0.43 kg (0.93 lb)

Agency Approvals: CE, UKCA, WEEE, RoHS

Note¹: Transmitter's calibrated at 22 °C (71 °F) nominal

Note²: Where *t* is the Absolute Value of temperature in Centigrade above or below 0 °C

Dimensions

NEMA 4X Enclosure (4X)

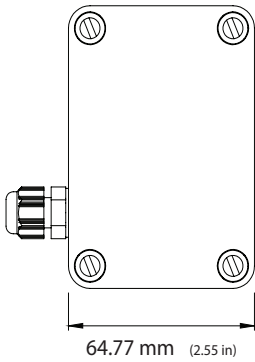

Front View

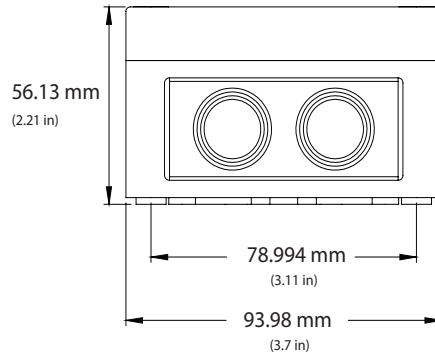

Side View

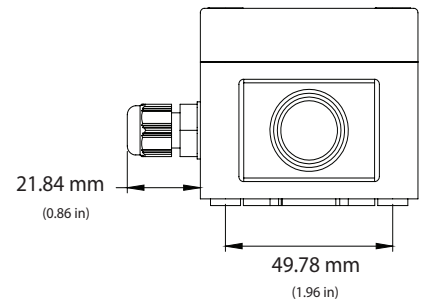

Top View

Galvanized Enclosure (GD)

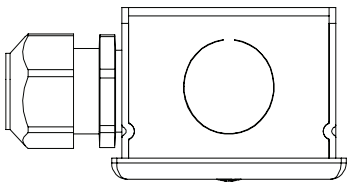

Front View

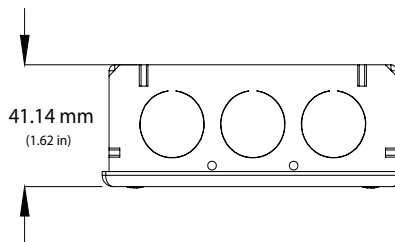

Side View

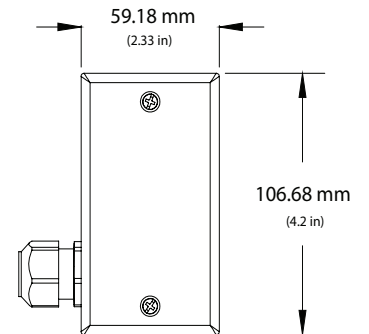

Top View



Bell Box Enclosure (BB)

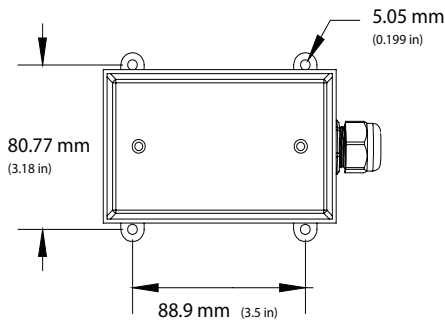

Front View

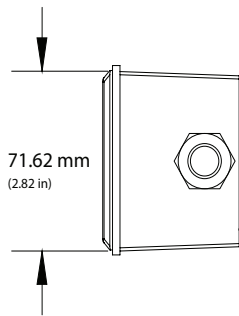

Side View

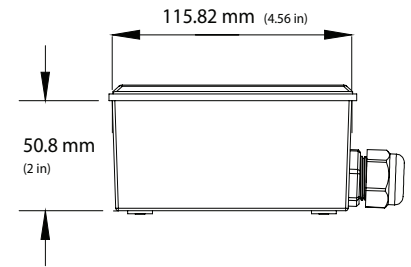

Top View

Sensor Probe



Front View

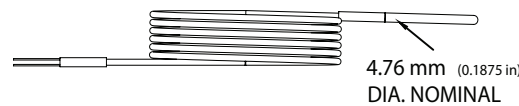

Side View

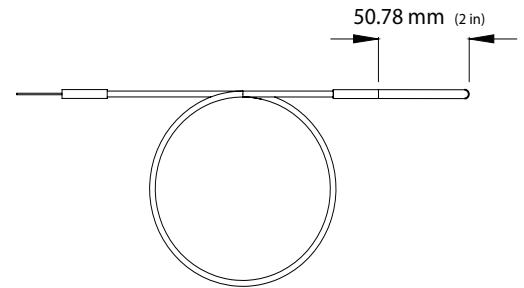

Top View

Optional Sensor Ordering

		Options and Descriptions			Model #
A. Sensor Series <i>No Selection Required</i>	A/	_____→			A/
		TT100 = 100 Ω RTD			
B. Model Series <i>Select One (1)</i>		TTM100 = Matched 100 Ω RTD*			
		TT1K = 1 kΩ RTD			
		TTM1K = Matched 1 kΩ RTD*			
C. Configuration <i>No Selection Required</i>	LTS = Freezer Sensor	_____→			LTS
D. Output Signal <i>Select One (1)</i>	1 = 1 V dc to 5 V dc (3-Wire)	2 = 2 V dc to 10 V dc (3-Wire)	4 = 4 mA to 20 mA (2-Wire Loop Powered)		
E. Enclosure <i>Select One (1)</i>	GD = Galvanized Enclosure	BB = NEMA 3R Enclosure	4X = NEMA 4X Enclosure		
F. Lead Length <i>Select One (1)</i>	10' = 3.05 m (10 ft) leads		30' = 9.15 m (30 ft) leads		
G. Calibration Span <i>Select One (1)</i>	Specify Span in °F or °C (Best Accuracy in 100 °F Increments)				
	Model # Example: A/ 1K LTS 4X 30' NIST				
	A. B. C. D. E. F.				

Note*: For TTM100 or TTM1k part numbers, the default NIST is 3 points | 5 points may be specified by using "-5PTNIST" at the end of any TTM part number.



Accessories Ordering

Model #	Description
-5PTNIST	5 Point Calibration & Certificate for TTM parts

