

Series S Sanitary Thermowells

Standard Threaded Well for 1/4 or 3/8" Diameter Elements

Application: 1/4 or 3/8" diameter stem, bimetal thermometers; temperature sensing elements having 0.252" (S-260 models) and 0.377" (S-385 models) maximum diameters, #20-gage thermocouple elements. Applications: food and beverage, pharmaceuticals, research.

Connection Size: 1 1/2, 2 and 2 1/2" Tri-Grip (Tri-Clamp® compatible) (flange size) are standard, 3 and 4" Tri-Grip models also available upon request.

Materials: 316 stainless steel. Custom wells are also available in special materials; prices on request.



74-05

1 1/2-S-260-U7 1/2-316SS shown smaller than actual size.

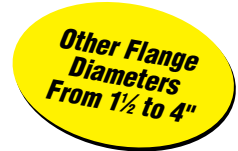

1 1/2-S-385-U1 5/8-316SS shown smaller than actual size.

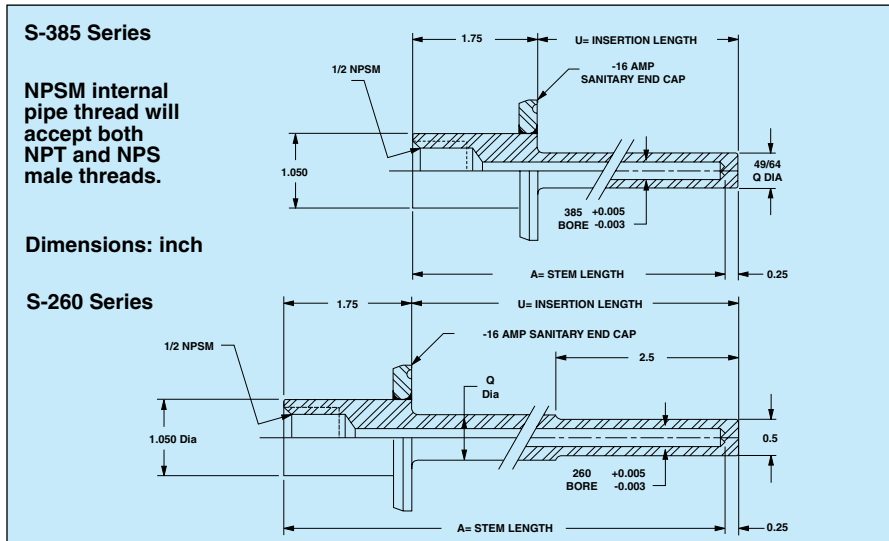

Pressure-Temperature Rating—lb per square inch							
Material	Temperature — °F						
	70°	200°	400°	600°	800°	1000°	1200°
A.I.S.I.-316	7000	7000	6400	6200	6100	5100	2500

To Order						
Model No.	Flange Size	Shank Style	Stem Length, A	Insertion Length, U	Shank Dia. Q	
S-260 Series* 0.260 Bore Diameter						
1 1/2-S-260-U1 5/8-316SS	1 and 1 1/2"	No step down	2 1/2	1 5/8"	1/2"	
1 1/2-S-260-U2 1/2-316SS	1 and 1 1/2"	No step down	4	2 1/2"	1/2"	
1 1/2-S-260-U4 1/2-316SS	1 and 1 1/2"	Step down	6	4 1/2"	3/4"	
1 1/2-S-260-U7 1/2-316SS	1 and 1 1/2"	Step down	9	7 1/2"	3/4"	
1 1/2-S-260-U10 1/2-316SS	1 and 1 1/2"	Step down	12	10 1/2"	3/4"	
2-S-260-U1 5/8-316SS	2"	No step down	2 1/2	1 5/8"	1/2"	
2-S-260-U2 1/2-316SS	2"	No step down	4	2 1/2"	1/2"	
2-S-260-U4 1/2-316SS	2"	Step down	6	4 1/2"	3/4"	
2-S-260-U7 1/2-316SS	2"	Step down	9	7 1/2"	3/4"	
2-S-260-U10 1/2-316SS	2"	Step down	12	10 1/2"	3/4"	
2 1/2-S-260-U1 5/8-316SS	2 1/2"	No step down	2 1/2	1 5/8"	1/2"	
2 1/2-S-260-U2 1/2-316SS	2 1/2"	No step down	4	2 1/2"	1/2"	
2 1/2-S-260-U4 1/2-316SS	2 1/2"	Step down	6	4 1/2"	3/4"	
2 1/2-S-260-U7 1/2-316SS	2 1/2"	Step down	9	7 1/2"	3/4"	
2 1/2-S-260-U10 1/2-316SS	2 1/2"	Step down	12	10 1/2"	3/4"	
S-385 Series* 0.385 Bore Diameter						
1 1/2-S-385-U1 5/8-316SS	1 and 1 1/2"	No step down	2 1/2	1 5/8"	49/64"	
1 1/2-S-385-U2 1/2-316SS	1 and 1 1/2"	No step down	4	2 1/2"	49/64"	

Ordering Examples: 1 1/2-S-260-U2 1/2-316SS, 1 1/2" Tri-Grip™ 316 SS sanitary well with 2 1/2" insertion length and 0.260" internal diameter.

1 1/2-S-260-U4 1/2-316SS, 1 1/2" Tri-Grip™ 316 SS step down sanitary well with 4 1/2" insertion length and 0.260" internal diameter.

1 1/2-S-260-U7 1/2-316SS, 1 1/2" Tri-Grip™ 316 SS sanitary well with 7 1/2" insertion length and 0.260" internal diameter.

*The above thermowells are also available with 3 and 4" Tri-Grip™ flanges, contact sales for ordering information.