

Smart Powered Strain Bridge/ Load Cell Conditioner

TXDIN1600s

- ✓ Suitable for load cell / strain gauge applications
- ✓ Universal current, bipolar voltage outputs
- ✓ Input range (0.2 to 7.5) mV/v, 5 v excitation
- ✓ Powered (10 to 32) v ac or (10 to 48) v dc supply
- ✓ (2 to 6) point calibration with active set option
- ✓ Remote tare, front panel push button configuration
- ✓ USB programmable



The TXDIN1600s is a “smart” powered bridge amplifier for use with strain gauges or load cell signals. The product has a built in capability to scale the input signal to a process value while the output stage offers either voltage, bipolar voltage or active / passive current re-transmission signals.

The TXDIN1600s requires an AC/DC power supply that will operate in the range (10 to 48) V DC and (10 to 32) V AC making the device ideal for battery operation. An additional volt free contact input is available for tare setting using a remote switch. The high precision input stage of the device allows for a bridge excitation voltage of 5V DC to be used as opposed to the traditional 10V DC. This reduces the power requirement for the bridge supply and up to four bridges (cells) may be connected to the input.

The device is provided with two front panel push buttons that can be configured to perform one of two functions or be disabled. Set as function 1, the buttons allow the user to push button configure the output range at high and low scale against a live input signal, set as function 2, the buttons allow the operator to trim the output at high and low scale. The device uses ratio metric measurement to obtain high stability.

The product uses a USB port for configuration, together with a simple to use menu driven software configuration tool, allowing the user to take advantage of the product’s comprehensive specification. Additionally, the user may read live process data when connected to the PC, allowing for offset and span calibration.

If configuration is not specified at the time of order, the product will be shipped with the default range 2 mV/V input (4 to 20) mA output.

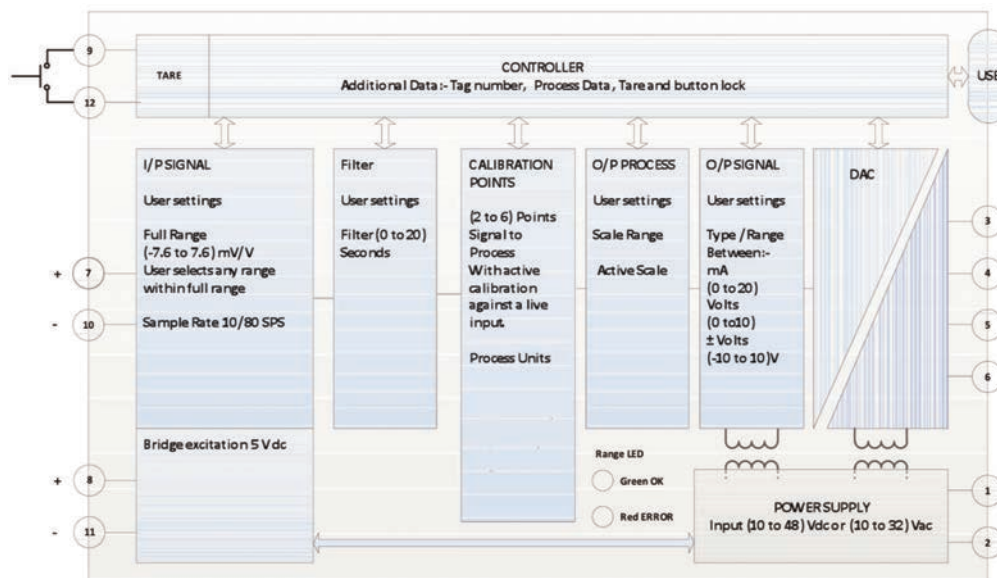

Specifications

BRIDGE INPUT

Full Range: (-7.6 to 7.6) mV/V (-38 to 38) mV @ 5V excitation

Type: Four Wire radiometric

Drift: $< \pm 0.05\%$

Linearity: $\pm 0.01\%$

Update: Selectable, 10 or 80 SPS (Samples per second)

BRIDGE EXCITATION

Voltage: 5 Volts DC $\pm 0.1\text{ V}$ @ 59 mA

Bridge Impedance: Total (85 to 10000) Ω (operates with four 350 Ω cell in parallel)

TARE INPUT

Type: Remote volt free contact, up to 10 metres distance

OUTPUT CURRENT

Current Source: Range (0 to 21.5) mA , Max Load 750 Ω

Current Sink: Range (0 to 21.5) mA , Supply (10 to 30) V dc, Voltage effect 0.2 uA/V

Accuracy: (mA Out/ 2000) or 5 uA which ever is the greater, Drift 1 uA/ $^{\circ}\text{C}$

OUTPUT VOLTAGE

Range: (0 to 10.1) V or (-10.1 to 10.1) V, Accuracy $\pm 5\text{ mV}$

Current Drive: $\pm 2\text{ mA}$, Min load 5000 Ω @ 10 V

PUSH BUTTON CONFIGURATION

Type: Independent "low" "High" front panel push buttons allow user to manually set low and high output points.

SUPPLY

Range: (10 to 48) VDC , (10 to 32) VAC Protected by internal 500 mA resettable fuse.

Power: $< 1\text{ W}$ Full Power

GENERAL

Isolation: Supply to input to output 500 V dc.

Indication: LED, Green when output (-0.1 to 100.1) %, else red

USER INTERFACE

Type: USB 2.0

Baud rate: 19,200 baud

Equipment: PC running windows XP or later, USB cable.

USER INTERFACE FUNCTIONS

Calibration Scaling: (2 to 6) points signal against process

Filter: (1 to 20) Seconds to reach 70 % of final value

Tare: Remote set tare offset with programmable user set point.

Active Calibration: Active Calibration against live load cell

Process Units: 4 Characters

Tag Number: 20 Characters

Process Output: Process Output Range

Signal Output: Select type, signal range

Active scaling output: Set output process range against active sensor input

Sensor Information: Model, sensitivity and balance

ENVIRONMENT

Operating Ambient: (-30 to 70) $^{\circ}\text{C}$; (10 to 90) %RH (non condensing)

Storage Ambient: (-30 to 70) $^{\circ}\text{C}$; (10 to 90) %RH (non condensing)

Configuration Ambient: (10 to 30) $^{\circ}\text{C}$

Installation Enclosure: DIN Rail enclosure offering Protection $\geq \text{IP65}$.

APPROVALS

CE: BS EN 61326

MECHANICAL

Style: DIN 43880, Colour grey, material Polyimide 6.6, weight $< 70\text{ grams}$

Terminals: 2.5 mm Maximum

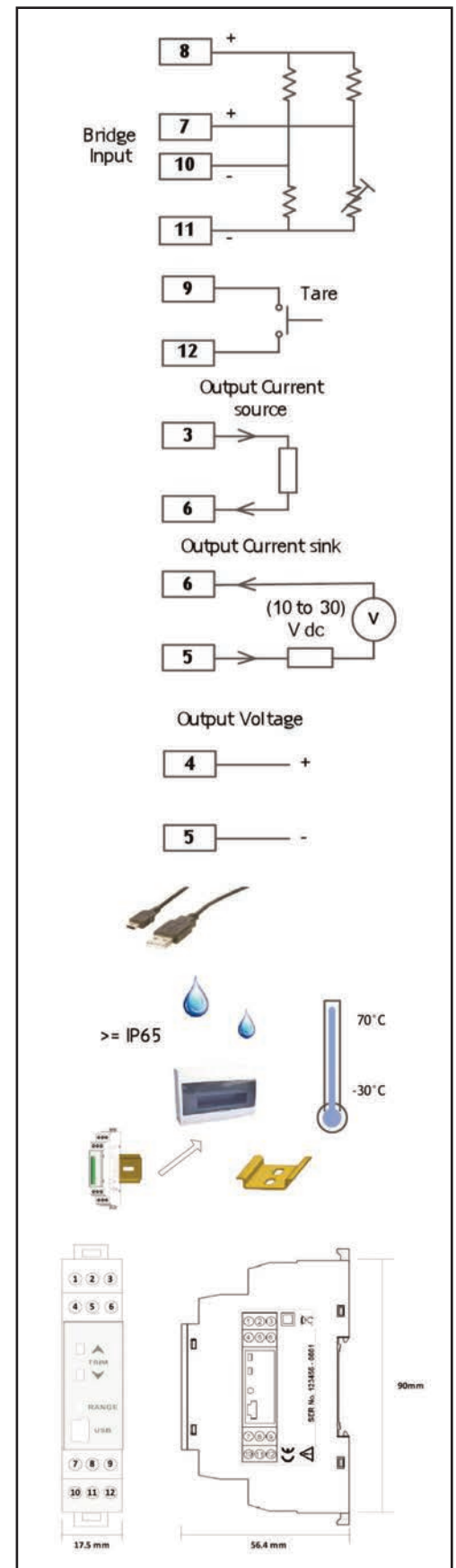

AVAILABLE FOR FAST DELIVERY!

To Order (Specify Model Number)

Model No.	Description
TXDIN1600s	DIN-Rail Mount Load-Cell Transmitter