

# Solid State Relays

## High Reliability, Vdc Input/ Vac Output, Vac Input/Vac Output



SSRL240AC10  
shown actual size.

### SSRL Series



- Current Ratings to 100 A
- Multi-Million Cycle Life
- Compatible with Temperature Controllers
- Solid-State, SCR Design
- Zero Voltage Switching
- Control AC Lines to 660 Vac
- AC and DC Control Signal Models
- LED Input Status Indicator
- Thermal Conductive Pad Included

The SSRL Series solid state relays are used to control large resistance heaters in conjunction with temperature controllers. Solid state relays are SPST, normally open switching devices with no moving parts, capable of millions of cycles of operation. By applying a control signal, an SSR switches “on” the AC load current, just as the moving contacts do on a mechanical contactor. Three-phase loads can be controlled using 2 or 3 SSR’s. Use 3 SSR’s for “Y” or “star” 3-phase loads using a neutral line. Two SSR’s will control “delta” loads with no neutral line. Three solid state relays are also used when there is no neutral load to provide redundancy and extra assurance of control.

“Switching” takes place at the 0 voltage crossover point of the alternating current cycle. Because of this, no appreciable electrical noise is generated, making SSR’s ideal for environments where there are apparatuses susceptible to RFI.

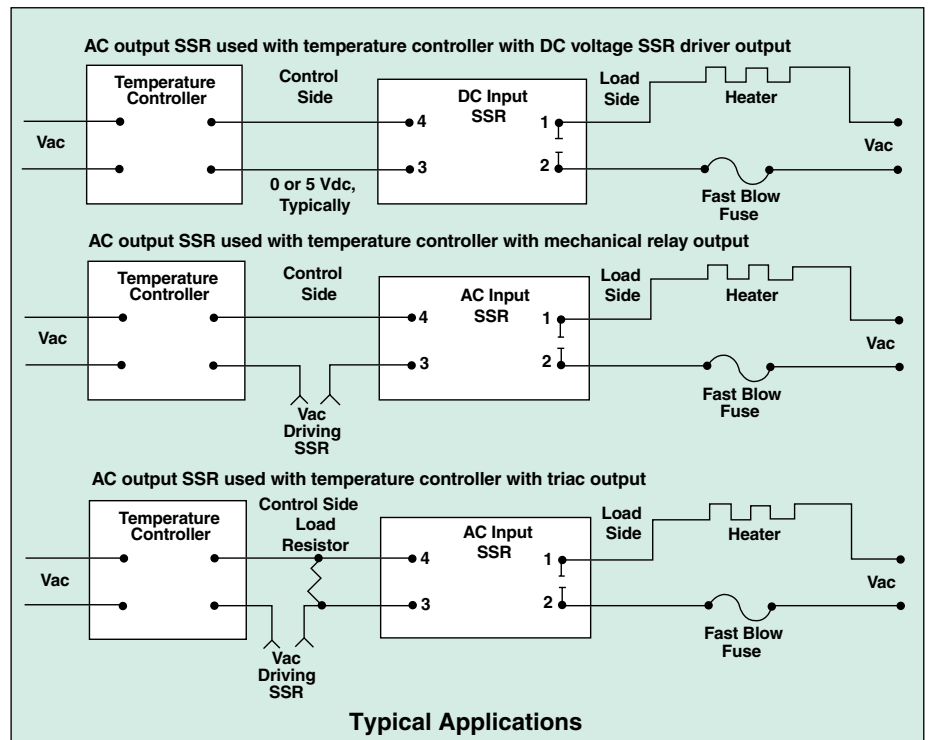

### Common Specifications

**Operating Temperature:** -20 to 80°C  
(-5 to 175°F)

**Storage Temperature:** -40 to 80°C  
(-40 to 175°F)

**Isolation:** 4000 Vrms, input to output;  
2500 Vrms input/output to ground

**Capacitance:** 8 pF, input to output (max)

**Line Frequency Range:** 47 to 63 Hz

**Turn-On Time:** 20 ms, AC; 05 cycle, DC

**Turn-Off Time:** 30 ms, AC; 05 cycle, DC

### Output Specifications for Vac and Vdc Input Models

Specifications	10 Amp	25 Amp	50 Amp	75 Amp	100 Amp
<b>Max On-State Current</b>	10 A	25 A	50 A	75 A	100 A
<b>Min On-State Current</b>	100 mA				
<b>Max 1-Cycle Surge</b>	150 A	300 A	750 A	1000 A	1200 A
<b>Max 1 sec Surge</b>	30 A	75 A	150 A	225 A	300 A
<b>1<sub>T</sub> (60 Hz), A<sub>2</sub>sec</b>	416	937	2458	5000	6000

These SSR's are of the twin SCR type, inherently more reliable and capable of higher overloads before failure than triacs. Heat is developed in a solid state relay due to the nominal voltage drop across the switching device. To dissipate the heat, an SSR must be mounted on a finned heat sink or aluminum plate. An SSR should be located where the ambient temperature is relatively low, since the current switching rating is lowered as the temperature increases. Another SSR characteristic is a small leakage current across the output when the relay is open. Because of this, a voltage will always exist on the load side of the device

In comparing SSR's with mechanical contactors, the SSR has a cycle life many times that of a comparably priced contactor. However, SSR's are more prone to failure due to overload and improper initial wiring. Solid state relays can fail, contact closed, on overload circuits. It is essential that a properly rated, fast blowing I<sup>2</sup>T fuse be installed to protect the load circuit

Finned heat sinks are anodized fabrications that come complete with tapped mounting holes and screws. See thermal rating curves and ordering instructions for proper selection.

All SSRL series relays come with a thermally conductive pad mounted on the baseplate. This will significantly improve the thermal conductivity between the heat sink and SSR baseplate. It is also suggested that 10<sup>3</sup>/lb of torque be used on the SSR mounting screws.



SSRL240DC50 solid state relay shown smaller than actual size with FHS-2 heat sink. See P-114 for more information.

### FHS Heat Sink Dimensions and Specifications

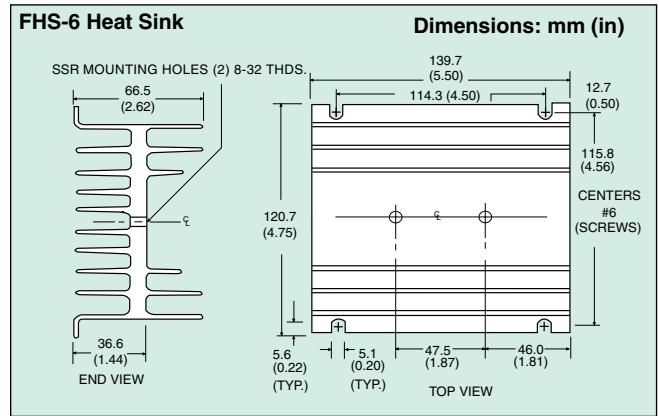
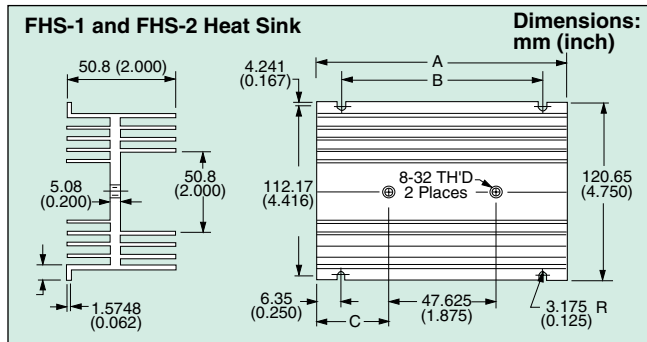

Model No.	A	B	C	Thermal Rating
FHS-1	3.00"	2.50"	0.56"	2°C/W
FHS-2	5.50"	5.00"	1.81"	1.2°C/W

### SSR240 Series Electrical Specifications

Model No.	Type	Input-Control Signal				Output
		Control Signal Voltage	Control Signal Turn-On	Control Signal Turn-Off	Max Input Current	Peak Voltage* (60 s Max)
SSRL240AC10 SSRL240AC25 SSRL240AC50 SSRL240AC75 SSRL240AC100	AC control signal	90 to 280 Vac	90 Vac	10 Vac	10 mA	800V
SSRL240DC10 SSRL240DC25 SSRL240DC50 SSRL240DC75 SSRL240DC100	DC control signal	3 to 32 Vdc	3 Vdc	1 Vdc	14 mA	800V
SSRL660AC50 SSRL660AC75 SSRL660AC100	AC control signal	90 to 280 Vac	90 Vac	10 Vac	10 mA	1200V
SSRL660DC50 SSRL660DC75 SSRL660DC100	DC control signal	4 to 32 Vdc	4 Vdc	1 Vdc	14 mA	1200V

\* Transients above table value should be suppressed.

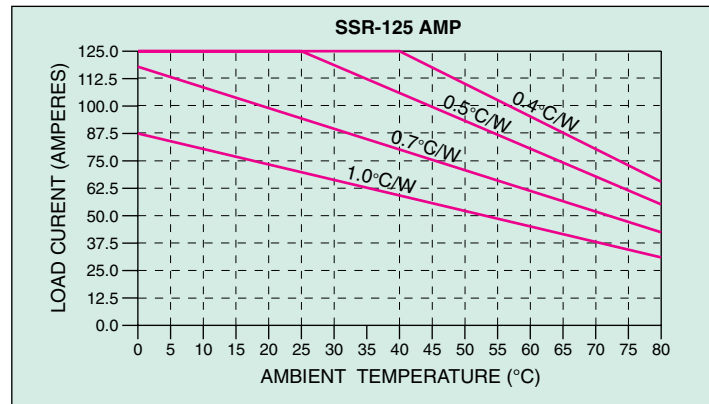
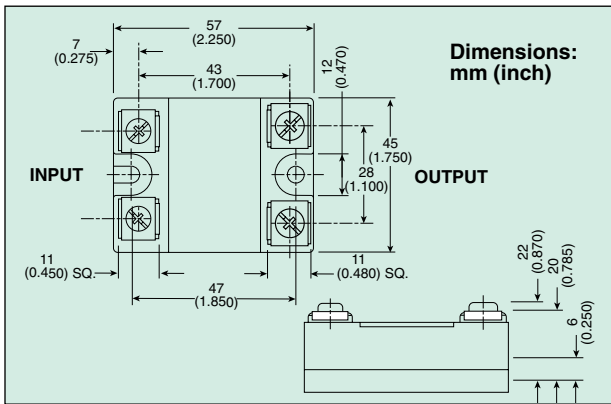
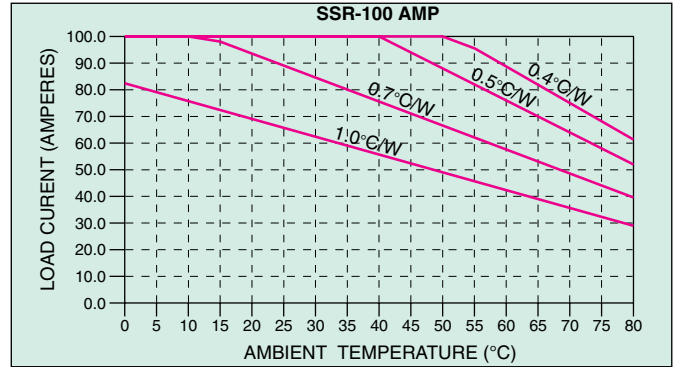
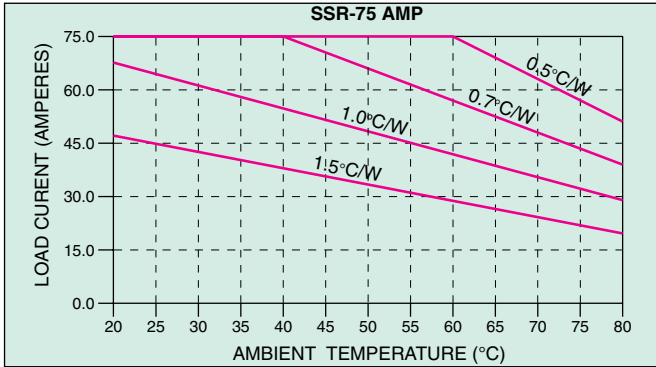
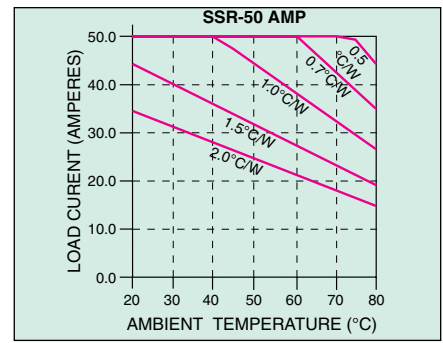
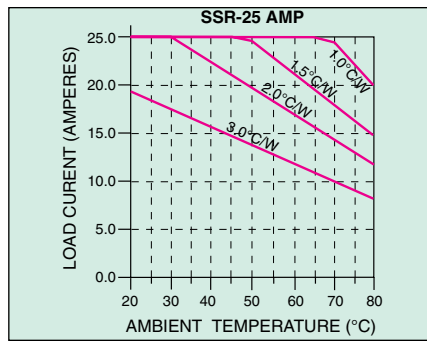
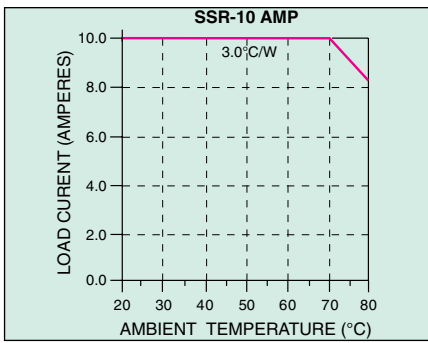

**SSR240 Series Output-Vac Load Specifications**

Model Number	Nominal AC Line Voltage	Nominal Load Current	Maximum Contact Voltage Drop	Maximum Off-State Leakage (25°C Maximum Ambient)		
				120 Vac	240 Vac	440 Vac
SSRL240AC10 SSRL240AC25 SSRL240AC50 SSRL240AC75 SSRL240AC100	24 to 280 Vac	10 A 25 A 50 A 75 A 100 A	1.6V	0.1 mA	0.1 mA	N/A
SSRL240DC10 SSRL240DC25 SSRL240DC50 SSRL240DC75 SSRL240DC100	24 to 280 Vac	10 A 25 A 50 A 75 A 100 A	1.6V	0.1 mA	0.1 mA	N/A
SSRL660AC50 SSRL660AC75 SSRL660AC100	48 to 660 Vac	50 A 75 A 100A	1.6V	0.25 mA	0.25 mA	0.25 mA
SSRL660DC50 SSRL660DC75 SSRL660DC100	48 to 660 Vac	50 A 75 A 100 A	1.6V	0.25 mA	0.25 mA	0.25 mA

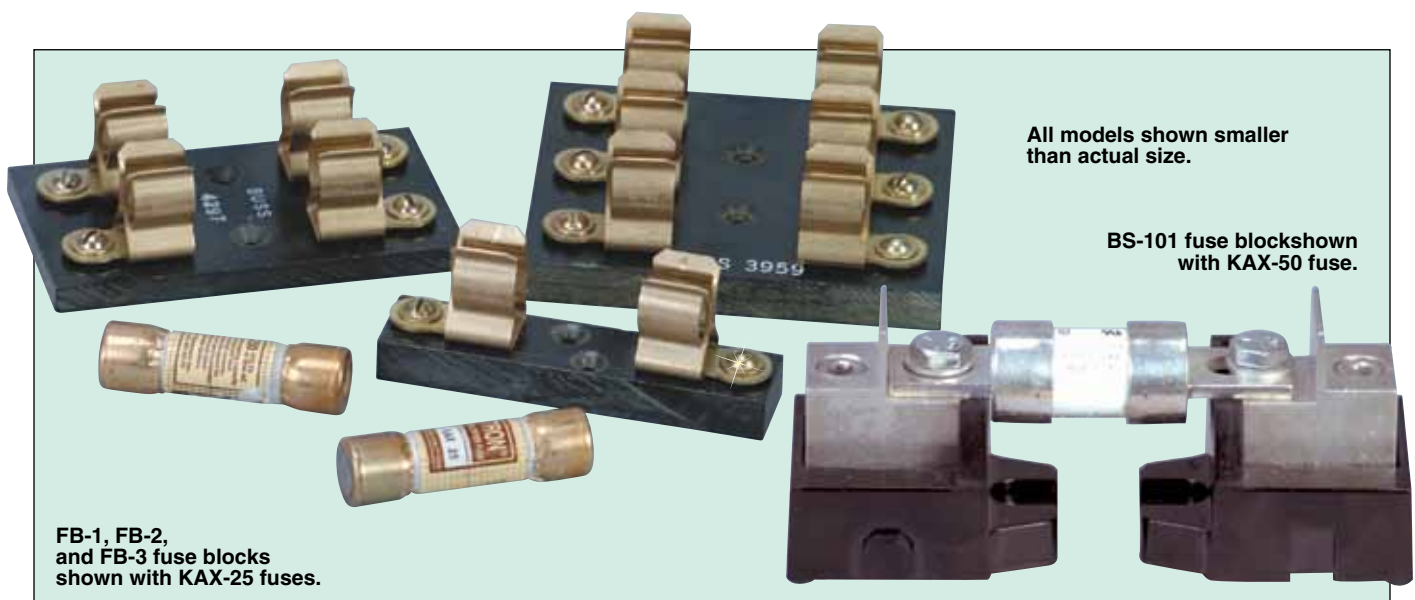

All models shown smaller than actual size.

BS-101 fuse block shown with KAX-50 fuse.

FB-1, FB-2, and FB-3 fuse blocks shown with KAX-25 fuses.

### Fuses

<b>To Order</b> Visit <a href="http://omega.com/ssrl240_660">omega.com/ssrl240_660</a> for Pricing and Details		
Model No.	Capacity	Dimensions (Dia. x L)
KAX-10	10 A	14 x 51 mm (0.6 x 2")
KAX-25	25 A	14 x 51 mm (0.6 x 2")
KAX-30	30 A	14 x 51 mm (0.6 x 2")
KAX-50	50 A	21 x 81 mm (0.8 x 3.2")
KAX-70	70 A	31 x 92 mm (1.2 x 3.6")
KBH-50	50 A	18 x 81 mm (0.7 x 3.2")
KBH-70	70 A	19 x 92 mm (0.7 x 3.6")

### Fuse Blocks

<b>To Order</b> Visit <a href="http://omega.com/ssrl240_660">omega.com/ssrl240_660</a> for Pricing and Details		
Model No.	No. of Fuses	Compatible Fuses
FB-1	1	KAX-10, KAX-25, KAX-30
FB-2	2	KAX-10, KAX-25, KAX-30
FB-3	3	KAX-10, KAX-25, KAX-30
BS-101	1	KAX-50, KAX-70, KAX-100, KBH (all models)

### Shunt Resistors for Controllers with AC SSR (Triac) Output

<b>To Order</b> Visit <a href="http://omega.com/ssrl240_660">omega.com/ssrl240_660</a> for Pricing and Details	
Model No.*	Value
SSRR20-12	2000 Ω, 12 watts
SSRR20-50	2000 Ω, 50 watts
SSRR15-12	1500 Ω, 12 watts
SSRR15-50	1500 Ω, 50 watts

\* 12 W versions for 120 V circuits; 50 W for 240 V.

### How to Order:

- 1) Select solid state relay based on type of control signal (AC or DC) and current switching requirements for resistive load.
- 2) Select fast blow (I<sup>2</sup>T) fuse and fuse block. It is essential that a fuse be installed to protect the load circuit.
- 3) Select required finned heat sink based on max ambient temperature and thermal rating curve on previous page.

<b>To Order</b> Visit <a href="http://omega.com/ssrl240_660">omega.com/ssrl240_660</a> for Pricing and Details		
Model No.	Description	Nominal Rating
SSRL240AC10	AC control signal (280 Vac line)	10 A
SSRL240AC25		25 A
SSRL240AC50		50 A
SSRL240AC75		75 A
SSRL240AC100		100 A
SSRL240DC10	DC control signal (280 Vac line)	10 A
SSRL240DC25		25 A
SSRL240DC50		50 A
SSRL240DC75		75 A
SSRL240DC100		100 A
SSRL660AC50	AC control signal (660 Vac line)	50 A
SSRL660AC75		75 A
SSRL660AC100		100 A
SSRL660DC50	DC control signal (660 Vac line)	50 A
SSRL660DC75		75 A
SSRL660DC100		100 A
FHS-1	Finned heat sink	2°C/W
FHS-2		1.2°C/W
FHS-6		0.7°C/W

### Accessory

Model No.	Description
SSRL-DINRAIL-ADAPT	DIN rail adaptor for 10 A models only

Comes complete with operator's manual.

Note: All SSRL Series come with thermally conducting pad. Reference SSR330 Series for additional heat sinks.

Ordering Examples: SSRL240DC25, solid state relay, FHS-2, finned heat sink, KAX-25, fuse, and FB-1, fuse block.

SSRL240AC10, solid state relay, FHS-1, finned heat sink, KAX-10, fuse, and FB-1, fuse block.